

# Health Insurance

Coverage And Employment Opportunities  
For Minorities And Women



According to the U.S. Bureau of the Census, in 1979 life insurance companies and medical service plans, the major health insurers, had an annual payroll of \$9.4 billion. This sum paid salaries and commissions for a work force composed almost entirely of white-collar employees.

There is evidence that minorities and women do not share equally with majority men in the economic security afforded by employment in the insurance industry or by insurance protection against health risks.



## **U.S. COMMISSION ON CIVIL RIGHTS**

The U.S. Commission on Civil Rights is a temporary independent, bipartisan agency established by Congress in 1957 and directed to:

- Investigate complaints alleging that citizens are being deprived of their right to vote by reason of their race, color, religion, sex, age, handicap, or national origin, or by reason of fraudulent practices;
- Study and collect information concerning legal developments constituting discrimination or a denial of equal protection of the laws under the Constitution because of race, color, religion, sex, age, handicap, or national origin, or in the administration of justice;
- Appraise Federal laws and policies with respect to discrimination or denial of equal protection of the laws because of race, color, religion, sex, age, handicap, or national origin, or in the administration of justice;
- Serve as a national clearinghouse for information in respect to discrimination or denial of equal protection of the laws because of race, color, religion, sex, age, handicap, or national origin;
- Submit reports, findings, and recommendations to the President and the Congress.

## **MEMBERS OF THE COMMISSION**

Clarence M. Pendleton, Jr., *Chairman*

Mary Louise Smith, *Vice Chairman*

Mary F. Berry

Blandina Cardenas Ramirez

Jill S. Ruckelshaus

Murray Saltzman

John Hope III, *Acting Staff Director*

This report was approved by former Commission Chairman Arthur S. Fleming, former Vice Chairman Mary F. Berry, former Commissioner Stephen Horn, and Commissioners Blandina Cardenas Ramirez, Jill S. Ruckelshaus, and Murray Saltzman.

# **Health Insurance**

## **Coverage And Employment Opportunities For Minorities And Women**

United States Commission on Civil Rights  
Clearinghouse Publication 72

September 1982

## Acknowledgments

---

The Commission is indebted to Sally Knack, project director, and to staff members Constance Hamilton, Lynne Heltman, Edna Laverdi, and Patricia O. Reynolds, who prepared this report under the direction of Ronald D. Henderson, Division Chief. The Commission also appreciates the contributions of staff members Henry Gordon and Linda Zimbler and student assistants Miguel Escalera and Larry Hales. Helpful comments were provided in the initial stage of the project by consultants Andrew Giffin, Harold Luft, and Lois Verbrugge. Support in preparing the report was provided by Diane Ferrier, Treola Grooms, Mary Moore, Cathy H. Somers, and Audrey Wright.

Eugene Platt edited the report. Final preparations for publication were handled by Vivian Hauser, Audree Holton, and Vivian Washington of the Publications Support Center.

The report was prepared under the overall supervision of Caroline Davis Gleiter, Assistant Staff Director, Office of Program and Policy Review.

# Contents

---

|   |    |
|---|----|
| 1. Introduction.....  | 1  |
| 2. Employment of Minorities and Women in the Insurance Industry ..... | 4  |
| 3. Health Insurance Coverage of Minorities and Women .....            | 15 |
| 4. Summary .....  | 39 |

## Appendices

|                                       |    |
|---------------------------------------|----|
| A. Methodology .....                  | 42 |
| B. Appendix Tables to Chapter 3 ..... | 51 |

## Tables

|   |    |
|---|----|
| 2.1 White-Collar Work Force in Selected Private Industries .....  | 5  |
| 2.2 Percentage Distribution of Insurance Industry and All U.S. Civilian Employees by Sex, Race, and Ethnicity: 1978.....                          | 6  |
| 2.3 Percentage Distribution of Insurance Industry Employees by Occupational Category and by Sex, Race, and Ethnicity: 1973-78 .....               | 7  |
| 2.4 Hiring and Promotion Rates for Minorities and Women, 1974-80.....   | 8  |
| 2.5 Percentages of Women and Minorities in Key Insurance Industry Occupations by Federal Contractor Status: 1973 and 1978 .....                   | 12 |
| 3.1 Percentage of Persons 14 to 64 Years Old with Health Insurance Coverage, by Employment Status, Race or Ethnicity, and Sex: 1976.....          | 20 |
| 3.2 Percentage of Employed Persons 14 to 64 Years Old with Health Insurance Coverage, by Occupation, Race or Ethnicity, and Sex: 1976.....        | 22 |
| 3.3 Percentage of Employed Persons 14 to 64 Years Old with Health Insurance, by Industry, Race or Ethnicity, and Sex: 1976.....                   | 23 |
| 3.4 Percentage of Persons 14 to 64 Years Old with Health Insurance, by Total Family Income in 1975, Race or Ethnicity, and Sex: 1976.....         | 28 |
| 3.5 Percentage of Persons 14 to 64 Years Old with Health Insurance Coverage, by Age, Race or Ethnicity, and Sex: 1976 .....                       | 29 |
| 3.6 Percentage of Women 14 to 64 Years Old with Health Insurance Coverage, by Marital Status and Race or Ethnicity: 1976 .....                    | 30 |
| 3.7 Percentage of Family Heads 14 to 64 Years Old with Health Insurance Coverage, by Employment Status, Race or Ethnicity, and Sex: 1976.....     | 32 |
| 3.8 Percentage of Children 0 to 13 Years Old with Health Insurance Coverage and of All Children by Family Income and Race or Ethnicity: 1976..... | 33 |
| 3.9 Comparisons of Covered Persons 14 to 64 Years Old With and Without Health Limitations, by Race or Ethnicity and Sex: 1976.....                | 36 |

|     |  |    |
|-----|--|----|
| A.1 | Population Under 65 Without Health Insurance, Based on Inclusion and Exclusion of Public Insurance Recipients, and on Race or Ethnicity: 1976 .....    | 46 |
| A.2 | Number of Unweighted Cases Used to Calculate Rates of Insurance Coverage in Text, Appendix Tables, and Figures .....                                   | 47 |
| B.1 | Percentage Distribution of Employed Persons 14 to 64 Years Old by Occupation, Race or Ethnicity, and Sex: 1976 .....                                   | 52 |
| B.2 | Percentage Distribution of Employed Persons 14 to 64 Years Old by Industry, Race or Ethnicity, and Sex: 1976 .....                                     | 53 |
| B.3 | Percentage of Employed Persons 14 to 64 Years Old with Health Insurance Coverage, by Class of Worker, Race or Ethnicity, and Sex: 1976 .....           | 54 |
| B.4 | Percentage of Employed Persons 14 to 64 Years Old with Health Insurance Coverage, By Full-time or Part-time Status, Race or Ethnicity, and Sex: 1976.. | 55 |
| B.5 | Percentage Distribution of Persons 14 to 64 Years Old by Total Family Income and Race or Ethnicity: 1976 .....   | 56 |
| B.6 | Percentage of Children 0 to 13 Years Old with Health Insurance Coverage, by Age and Race or Ethnicity: 1976 .....                                      | 56 |

**Figures**

|     |   |    |
|-----|---|----|
| 3.1 | Percentage of Persons 14 to 64 Years Old with Health Insurance Coverage, by Race or Ethnicity and Sex: 1976 ..... | 18 |
| 3.2 | Percentage of Family Heads 14 to 64 Old with Health Insurance Coverage, by Race or Ethnicity, and Sex: 1976 ..... | 31 |

## Introduction

The health insurance industry is a vital part of economic life in this country. Health insurance helps policyholders meet the cost of physician and hospital care required in treating illnesses and injuries. These health care costs have risen at a faster rate than the prices of other important consumer goods. For example, between 1967 and 1980, while food prices increased about 2.5 times, hospital room charges more than quadrupled.<sup>1</sup> Medical expenses for catastrophic illness (those in excess of \$5,000 per year) place an especially severe financial burden on many families. In 1974 the costs of catastrophic illness for noninstitutionalized people under 65 totaled about \$6.2 billion.<sup>2</sup> Of this amount, approximately \$330 million was incurred by people who lacked private insurance and were ineligible for medicaid or medicare and, thus, were most vulnerable to financial loss.<sup>3</sup> Private health insurance provides a measure of protection against such

overwhelming medical care expenses. In 1980 private insurers paid \$58.1 billion in benefits to cover personal health care expenditures.<sup>4</sup> Although this did not pay all health care costs, it represented a substantial economic cushion unavailable to persons without health insurance.

The industry is also a significant source of earnings income. According to the U.S. Bureau of the Census, in 1979 life insurance companies and medical service plans, the major health insurers, had an annual payroll of \$9.4 billion.<sup>5</sup> This sum paid salaries and commissions for a work force composed almost entirely of white-collar employees.<sup>6</sup>

There is evidence that minorities and women do not share equally with majority men in the economic security afforded by employment in the insurance industry or by insurance protection against health risks.<sup>7</sup> At a consultation held in 1978 by the U.S. Commission on Civil Rights on insurance issues,

<sup>1</sup> Health Insurance Institute, *1980-1981 Source Book of Health Insurance Data* (Washington, D.C.: Health Insurance Association of America), pp. 63 and 65 (hereafter cited as *Source Book*). Price rises quoted are based on changes in the Consumer Price Index (CPI) prepared by the Bureau of Labor Statistics (BLS). In 1978, BLS made some changes in the CPI. It added a new index for all urban consumers that covers about 80 percent of the total noninstitutional population. Further, it revised the index for urban wage earners and clerical workers (which is about half the new index population) to reflect changes in the market basket of goods purchased by consumers. Price rises quoted here compare the old index for urban wage earners and clerical workers with the new index for all urban workers. Although the two index numbers differ somewhat, they do not alter the comparative relationship in increases between hospital room charges and food prices.

<sup>2</sup> *Ibid.*, p. 73.

<sup>3</sup> *Ibid.* Medicaid, established in 1966 under the Social Security Act, provides medical assistance to certain low-income persons, including the aged, blind, and disabled and members of families with dependent children. The program is State administered, but

Federal matching funds cover a portion of the cost. 42 U.S.C. §§1392-96k (1976 and Supp. III 1979). Medicare, also established in 1966 under the Social Security Act, is a Federal health insurance program for persons age 65 years or older, for permanently disabled workers and their dependents who are eligible for Old Age, Survivors, Disability, and Health Insurance, and for persons with severe renal disease. 42 U.S.C. §§1395-95rr (1976 and Supp. III 1979).

<sup>4</sup> Robert M. Gibson and Daniel R. Waldo, "National Health Expenditures, 1980," *Health Care Financing Review*, September 1981, p. 20. Premiums to cover these benefit payments as well as administrative costs, reserve requirements, and a profit return amounted to \$64.9 billion. *Ibid.*, pp. 11 and 17.

<sup>5</sup> U.S., Department of Commerce, Bureau of the Census, *County Business Patterns 1979*, no. CBP-79-1, p. 73.

<sup>6</sup> See chap. 2.

<sup>7</sup> The term "majority" used in this report is equivalent to the term "white, not of Hispanic origin," since white Hispanics are classified as Hispanic. Similarly, the term "black" means "black, not of Hispanic origin." By this definition, any one individual can

participants testified that women and racial and ethnic minorities are underrepresented in management and policy positions and in educational programs that would prepare them for advancement.<sup>8</sup> Some industry underwriting and marketing practices also adversely affect the ability of minorities and women to obtain health insurance. Since insurers can fulfill their role of providing insurance protection only as long as they remain financially solvent, they must necessarily be concerned with the potential insured's health and ability to pay premiums. Thus, in underwriting, insurance companies consider health condition and socioeconomic characteristics, such as employment status, occupation, industry, and income, that are associated with variations in risk.<sup>9</sup> To the extent that minorities and women are more likely than majority men to possess higher risk socioeconomic characteristics, then they have greater difficulty in acquiring coverage. Socioeconomic differences aside, however, participants in the consultation noted that the industry has, on occasion, been slow to realize the potential market of women and racial and ethnic minorities who are insurable risks.<sup>10</sup> Further, the industry has not always had adequate information to assess the insurability of groups with which it has had little experience.<sup>11</sup>

be classified into only one race or ethnic category. Thus, the summation of each of the five categories used throughout this report (majority, black, Hispanic, Asian and Pacific Island American, and American Indian) will equal the total population. The term "white" is used to denote "white, including those of Hispanic origin" and is, as such, not synonymous with the term "majority." The term "white" is used to indicate the use of data from Bureau of the Census reports and various other sources where white Hispanics have been categorized as "white."

<sup>8</sup> Herbert S. Denenberg, "An Overview Report: Discrimination in the Insurance Marketplace and in the Insurance Business—With Primary Emphasis on Life, Health, Disability, and Pensions," in U.S., Commission on Civil Rights, *Discrimination Against Minorities and Women in Pensions and Health, Life, and Disability Insurance*, vol. 1 (1978), pp. 174–276 (hereafter cited as *Consultation*); F. Marion Fletcher and Linda Pickthorne Fletcher, "Employment Patterns of Minorities and Women in the Insurance Industry, 1966–75," *Ibid.*, pp. 614–53; and Cruz Alderete, "Comments," *Ibid.*, p. 750.

<sup>9</sup> Davis W. Gregg and Vane B. Lucas, ed., *Life and Health Insurance Handbook* (Homewood, Ill.: Richard D. Irwin, Inc., 1973), pp. 338–45 and 433–45, (hereafter cited as *Handbook*).

<sup>10</sup> Denenberg, "Overview Report," *Consultation*, vol. 1, pp. 266–69, 273–74, 277–78; Naomi Naierman and Ruth Brannon, "Sex Discrimination in Insurance," *Ibid.*, pp. 480–83; E.P. Vecchio and Oscar Cerda, "Discrimination Against Farmworkers in the Insurance Industry," *Ibid.*, pp. 519–26; Robert J. Randall, "Risk Classification and Actuarial Tables as They Affect Insurance Pricing for Women and Minorities," *Ibid.*, pp. 537–38, 541–42, 550–61, 607–8; Linda Lamel, "State Regulation of the Insurance Industry," *Ibid.*, pp. 677–88; William J. Sheppard and Gayle Lewis-Carter, "Discrimination in the Insurance Marketplace: A

Therefore, in employment and the provision of health insurance coverage—two integral aspects of the insurance industry—minorities and women are not provided with opportunities equal to those being given to majority men.

These disparities exist despite the protections afforded by Federal and State agencies responsible for assuring compliance with laws affecting minorities and women in their roles as employees and policyholders. Federal and State civil rights agencies, for example, are charged with enforcing compliance with fair employment practices laws.<sup>12</sup> State insurance departments have some influence on employment through their powers to set standards for and license agents and brokers.<sup>13</sup> In addition, State insurance departments administer laws that affect whether and under what circumstances people obtain private health insurance.<sup>14</sup> Among these are codes and regulations specifically barring unfair discrimination on the basis of race, national origin, religion, and sex in issuing or renewing insurance.<sup>15</sup> Unfair discrimination is an insurance term referring

Pennsylvania Overview," *Ibid.*, pp. 707–19; and Cruz Alderete, "Comments," *Ibid.*, p. 750.

<sup>11</sup> Denenberg, "Overview Report," *Ibid.*, pp. 261–62, 269–71, 277–79; Vecchio and Cerda, "Discrimination Against Farmworkers in the Insurance Industry," *Ibid.*, p. 522; and Remarks by Cruz Alderete, *Ibid.*, pp. 240 and 246.

<sup>12</sup> See chap. 2.

<sup>13</sup> *Ibid.*

<sup>14</sup> Lamel, "State Regulation of the Insurance Industry," *Consultation*, vol. 1, pp. 668–90.

<sup>15</sup> For laws barring discrimination on the basis of race, national origin, and religion, see Ark. Stat. Ann. §66–3005(7)(g); Cal. Ins. Code §10140 (West); Fla. Stat. §626.9541 (24) (Supp. 1979); Ill. Ann. Stat. ch. 73, §1031 (3) (Smith-Hurd Supp. 1981–82); Ky. Rev. Stat. §304.12–085 (Supp. 1980); Md. Ann. Code art. 48A, §234A; Mich. Comp. Laws Ann. §500.2027; Mo. Ann. Stat. §375.007 (Vernon Supp. 1980); N.H. Rev. Stat. Ann. §417:4 (VIII)(e)(Supp. 1977); N.J. Stat. Ann. §17B:30–12(b) (West Supp. 1980); N.Y. Ins. Code §27–40e (McKinney Supp. 1980–81); N.D. Cent. Code §26–30–04(11); Pa. Stat. Ann. tit. 40, §1171.5 (iii)(Purdon Supp. 1980–81); Utah Code Ann. §13–7–1; Wash. Rev. Code Ann. §49.60.030(1). One of these States, Kentucky, prohibits refusal to insure or renew a policy based on race, color, religion, national origin, or sex. However, it permits the use of race classification in ratemaking when "determined through valid actuarial tables." Ky. Rev. Stat. §304.12–085 (Supp. 1980). For regulations relating to sex discrimination, see "Model Regulation to Eliminate Unfair Sex Discrimination," *Official NAIC Model Laws, Regulations and Guidelines* (Minneapolis, Minn.: NIARS Corp., 1977), vol.1, pp. 160–1 to 160–5 (hereafter cited as *NAIC Model Laws*).



to dissimilar treatment in rates, underwriting, and policy benefits of persons of similar risk.<sup>16</sup>

To assist high risk individuals who are unable to obtain insurance or who do not have adequate insurance to meet extraordinary health care expenses, some legislatures have enacted State-mandated health insurance programs patterned, in part, after model laws developed by the National Association of Insurance Commissioners, an affiliate organization of State insurance agency heads.<sup>17</sup> Some are comprehensive health plans whose purpose is to remove financial and access barriers to needed preventive and rehabilitative care.<sup>18</sup> Others are catastrophic care plans whose purpose is to provide protection against the high costs of serious illness or injury.<sup>19</sup> A number of national health insurance proposals have also been introduced and discussed in the U.S. Congress.<sup>20</sup> These, too, would either provide comprehensive or catastrophic coverage.<sup>21</sup>

As a followup to the Commission's 1978 consultation, this report provides a statistical analysis of the employment and occupational status of minorities and women in life insurance companies and medical service plans and the extent to which these groups have health insurance.<sup>22</sup> Because the private health

insurance market is the focus of attention, persons who have or are eligible for medicaid or medicare are omitted from the analysis of health insurance coverage rates. Throughout, comparisons are made with the occupational patterns and incidence of health insurance coverage among majority men. These comparisons are "social indicators of equality."<sup>23</sup> Similar outcomes provide some measure of the extent to which health insurance and employment opportunities are made available on an equitable basis. Disparate outcomes, especially among those whose insurability or ability to pay premiums is not in question, indicate potential minority or female markets that the industry can serve but is not reaching. Low coverage rates among minorities and women whose health or socioeconomic condition make them less desirable risks in the eyes of private insurers point to the need for additional Federal and State assistance in meeting health care costs. Access to insurance protection and good medical care are fundamental to national well-being. These should not be precluded by socioeconomic conditions that are, in part, the result of past and present discrimination against minorities and women in jobs and other aspects of their lives.<sup>24</sup>

<sup>16</sup> Richard Minck, "Discrimination Against Minorities and Women in Pensions and Health, Life, and Disability Insurance: The Insurance Industry Response," *Consultation*, vol. 1, p. 725.

<sup>17</sup> "Catastrophic Health Insurance Model Act," *NAIC Model Laws*, vol. 1, pp. 70-1 to 70-10, and "Comprehensive Health Insurance and Health Care Cost Containment Model Act," *NAIC Model Laws*, vol. 1, pp. 80-1 to 80-31.

<sup>18</sup> "Comprehensive Health Insurance and Health Care Cost Containment Model Act," *NAIC Model Laws*, vol. 1, pp. 80-1 to 80-31.

<sup>19</sup> "Catastrophic Health Insurance Model Act," *NAIC Model Laws*, vol. 1, pp. 70-1 to 70-10.

<sup>20</sup> Karen Davis, *National Health Insurance: Benefits, Costs, and Consequences* (Washington, D.C.: The Brookings Institution, 1975), and Judith Feder, John Holahan, and Theodore Marmor, ed., *National Health Insurance: Conflicting Goals and Policy Choices* (Washington, D.C.: The Urban Institute, 1980).

<sup>21</sup> *Ibid.*

<sup>22</sup> Life insurance companies sell other lines of insurance in addition to health insurance. The data sources used for analysis of employment patterns in these companies do not distinguish between staff assigned to health insurance activities and those working in other lines of business. See further discussion in appendix A, methodology.

<sup>23</sup> U.S., Commission on Civil Rights, *Social Indicators of Equality for Minorities and Women* (August 1978), pp. 1-4 (hereafter cited as *Social Indicators*).

<sup>24</sup> In its recent publication *Affirmative Action in the 1980s: Dismantling the Process of Discrimination* the U.S. Commission on Civil Rights points to structural discrimination—a self-sustaining, circular discriminatory process—as a major reason for continuing and persistent inequalities among majority men, minorities, and women. "Discrimination in education denies the credential to get good jobs. Discrimination in employment denies the economic resources" to buy insurance, meet the costs of health services, and purchase food for an adequate diet. U.S., Commission on Civil Rights, *Affirmative Action in the 1980s: Dismantling the Process of Discrimination* (November 1981), p. 11. For information on nutritional deficiencies and differences in utilization of health services, see U.S., Department of Health, Education, and Welfare, Public Health Service, *Health Status of Minorities and Low-Income Groups*, DHEW publication no. (HRA) 79-627 (1979). In addition, minorities and women are subject to discrimination in the delivery of health services. Naomi Naerman and others, *Sex Discrimination in Health and Human Development Services*, a report prepared for the Office for Civil Rights, Department of Health, Education, and Welfare (June 1979), and U.S., Commission on Civil Rights, *Civil Rights Issues in Health Care Delivery* (April 1980). Poor health, in turn, affects individual ability to purchase insurance and, for children, the extent to which full advantage can be taken of the education provided.

## Employment of Minorities and Women in the Insurance Industry

The insurance industry is an important source of employment, especially for white-collar occupations.<sup>1</sup> According to 1979 data published by the Equal Employment Opportunity Commission (EEOC), life insurance companies and medical service plans employ 97 percent of their workers in white-collar jobs. As shown in table 2.1, that figure is significantly greater than for other large private industries.

This chapter examines the participation of minorities and women in different occupational classifications and the progress or lack of progress they have made as employees in white-collar occupations in the insurance industry to determine whether they are now adequately represented in these occupations. It also examines government equal employment enforcement programs to ascertain whether these programs are being adequately administered with respect to the insurance industry. Employment data are provided by the Equal Employment Opportunity Commission for the years 1973 and 1978 and by the Clearinghouse on Corporate Social Responsibility for 1974 through 1980.<sup>2</sup>

### Hiring and Promotion Patterns

EEOC data show that in 1978 women represented

over half (54.1 percent) of the insurance industry work force and only 40.7 percent of all employed persons. (See table 2.2.) This overrepresentation of women in the insurance industry is not a recent phenomenon. As one insurer has stated: "Women have always been the backbone of our labor force."<sup>3</sup> Given current occupational patterns, it is the office and clerical workers who are the "backbone" of the insurance industry, for this is the category in which women are most heavily concentrated. (See table 2.3.) In 1978 about two-thirds of all women employed by life and health insurers were office and clerical workers. Black and Hispanic women were more concentrated than majority women in office and clerical occupations. In 1978, 74.9 percent of the Hispanic women and 71.8 percent of the black women employed by life, accident, and health insurance firms and hospital and medical service firms were office and clerical workers compared with 66.9 percent of majority women. The concentration of Asian and Pacific Island American and American Indian women in clerical jobs was about equal to that for majority women.

All women, and especially minority women, are poorly represented as managers, professionals, and sales workers in the insurance industry. In 1978, for

<sup>1</sup> The nature of the insurance business accounts for the high proportion of white-collar workers. Unlike industry or agriculture, blue-collar jobs are not available in significant numbers.

<sup>2</sup> Data from both of the sources are for life insurance companies and medical service plans, the major health insurers. Life insurance companies market lines of insurance other than health insurance. The data sources, however, do not distinguish employees assigned only to health insurance activities. Thus, references

made here to insurance industry employment include some life insurance company employees whose responsibilities extend to other lines of insurance, primarily life and disability insurance and annuities.

<sup>3</sup> Clearinghouse on Corporate Social Responsibility, *1980 Social Report of the Life & Health Insurance Business* (October 1980), p. 17.

example, 21 percent of the insurance industry's work force was in sales. Less than 5 percent of all women were in sales, however. Similarly, while 14 percent of all insurance industry employees were managers in 1978, only 5.3 percent of majority women, 2.6 percent of black women, and even smaller percentages of Hispanic and Asian and Pacific Island American women were employed as managers in this industry. These percentages, however, do represent a slight increase for both majority and minority women in the past 5 years. In 1973, for instance, 3.9 percent of majority women and 1.5 percent of black women were managers. (See table 2.3.)

Somewhat different employment patterns prevail for majority and minority men. In 1978 men represented 59.3 percent of the general labor force and 45.8 percent of employees in the insurance industry. Minority men were 5.2 percent of insurance industry employees in 1978 compared with 8.9 percent of the general labor force. (See table 2.2.)

In examining the occupational distribution of male workers, disparities between majority and minority men are apparent. Majority men are concentrated in the white-collar occupations of managers, professionals, and sales workers. (See table 2.3.) Of these three occupations, the concentration of minority men approximates that of majority men only in sales positions, primarily in marketing and underwriting. In 1978 about 40 percent of black men and 41 percent of Hispanic men were sales workers. This compares favorably with majority men, about 42 percent of whom were sales workers. American

Indian and Asian and Pacific Island American men were somewhat less often found in sales (35 percent). Minority men, particularly black and Hispanic men, are not equally well represented in the managerial and professional occupations where marketing and underwriting policies and guidelines are established. Nearly 45 percent of majority men are managers and professionals compared with about 23 percent of black and Hispanic men. This represents some improvement for black and Hispanic men since 1973 when about 18 and 15 percent, respectively, were managers and professionals. Some gains were also made by Asian and Pacific Island American men in managerial positions. For instance, in 1973, 6.9 percent were managers compared to 11.2 percent in 1978. Similarly, American Indians gained in employment within professional positions, rising from 13.6 percent in 1973 to 20.4 percent in 1978.

Data on hiring and promotion patterns reported by the Clearinghouse on Corporate Social Responsibility provide some explanation for the slow gains made by minorities and women in key positions, such as sales, management, and professional jobs. (See table 2.4.) Between 1974 and 1980, the vast majority of newly hired women were placed in office and clerical positions where they were already overrepresented. In 1974 almost 90 percent of newly hired women were placed in office and clerical positions. In 1980 newly hired women were still overwhelmingly placed in office and clerical positions, but the percentage had decreased to 78.5 percent. Although there were some modest gains in the proportion of minority and female "new hires"

**TABLE 2.1**  
**White-Collar Work Force in Selected Private Industries**

| Industry                | Percentage of white-collar jobs |
|-------------------------|---------------------------------|
| Insurance*              | 97                              |
| Communications          | 72                              |
| Utility services        | 53                              |
| Printing & publishing   | 52                              |
| Mining                  | 35                              |
| Transportation          | 33                              |
| Food & kindred products | 32                              |
| Construction            | 28                              |
| Agriculture             | 22                              |

\*Includes life insurance companies and medical service plans, the primary health insurers.

Source: U.S., Equal Employment Opportunity Commission, *Equal Employment Opportunity Report: Minorities and Women in Private Industry* (September 1981).

**TABLE 2.2****Percentage Distribution of Insurance Industry and All U.S. Civilian Employees by Sex, Race, and Ethnicity: 1978<sup>a</sup>**

|                  | Type of labor force        |                                |
|------------------|----------------------------|--------------------------------|
|                  | <i>Insurance</i>           | <i>U.S. civilian employees</i> |
| Men              | 45.8                       | 59.3 <sup>*</sup>              |
| Majority         | 40.7                       | 50.4                           |
| Black            | 3.3                        | 5.1                            |
| Hispanic         | 1.1                        | 2.9                            |
| Asian & Pacific  |                            |                                |
| Island American  | 0.6                        | 0.9 <sup>c</sup>               |
| American Indian  | 0.2                        | <sup>c</sup>                   |
| Women            | 54.1                       | 40.7                           |
| Majority         | 43.4                       | 33.6                           |
| Black            | 7.8                        | 4.6                            |
| Hispanic         | 1.8                        | 1.7                            |
| Asian & Pacific  |                            |                                |
| Island American  | 0.9                        | 0.8 <sup>c</sup>               |
| American Indian  | 0.2                        | <sup>c</sup>                   |
| Total employment | 100 <sup>b</sup> (877,063) | 100 (86,392,000)               |

<sup>a</sup> Industry employment includes only those working in life, accident, and health insurance firms and hospital and medical service plans (SIC 631 and 632).

<sup>b</sup> Percentages may not sum to 100 due to rounding.

<sup>c</sup> The data were not reported in a way to calculate separately the percentages which American Indians and Asian and Pacific Island Americans are in the employed civilian labor force.

\* This can be interpreted as follows: In 1978, 59.3 percent of noninstitutionalized civilians employed in the United States were men. Source: U.S. Equal Employment Opportunity Commission—Special tabulations of EEO-1 data used to provide insurance industry data, and U.S., Department of Labor, 1980 *Employment Record*, pp. 221—23 and 231—32.

**TABLE 2.3****Percentage Distribution of Insurance Industry Employees by Occupational Category and by Sex, Race, and Ethnicity: 1973 and 1978<sup>a</sup>**

|                                    | Managers |      | Professionals |      | Technicians |      | Sales |      | Office & clericals |      | Other occupations |      | Total <sup>b</sup> |      |
|------------------------------------|----------|------|---------------|------|-------------|------|-------|------|--------------------|------|-------------------|------|--------------------|------|
|                                    | 1973     | 1978 | 1973          | 1978 | 1973        | 1978 | 1973  | 1978 | 1973               | 1978 | 1973              | 1978 | 1973               | 1978 |
| Both sexes                         | 12.8*    | 14.0 | 10.5          | 12.4 | 6.4         | 10.1 | 24.8  | 21.0 | 42.3               | 39.6 | 3.2               | 2.9  | 100                | 100  |
| Men                                | 22.0     | 24.9 | 15.4          | 16.9 | 5.8         | 6.4  | 45.8  | 41.8 | 7.1                | 6.3  | 3.9               | 3.6  | 100                | 100  |
| Majority                           | 23.2     | 26.6 | 16.0          | 17.4 | 5.8         | 6.0  | 46.1  | 42.1 | 6.1                | 4.9  | 2.9               | 3.0  | 100                | 100  |
| Black                              | 9.7      | 11.6 | 8.0           | 11.2 | 5.4         | 8.5  | 44.5  | 39.6 | 16.6               | 18.1 | 15.7              | 11.1 | 100                | 100  |
| Hispanic                           | 8.3      | 12.2 | 7.1           | 11.6 | 6.3         | 9.2  | 43.2  | 41.3 | 20.0               | 15.5 | 15.0              | 10.6 | 100                | 100  |
| Asian & Pacific<br>Island American | 6.9      | 11.2 | 20.5          | 18.8 | 12.2        | 14.3 | 28.1  | 34.8 | 30.1               | 17.4 | 2.4               | 3.4  | 100                | 100  |
| American Indians                   | 21.3     | 18.9 | 13.6          | 20.4 | 2.9         | 15.0 | 50.5  | 35.3 | 7.7                | 5.9  | 4.0               | 4.6  | 100                | 100  |
| Women                              | 3.5      | 4.8  | 5.6           | 8.6  | 7.1         | 13.2 | 3.4   | 3.4  | 78.1               | 67.8 | 2.3               | 2.1  | 100                | 100  |
| Majority                           | 3.9      | 5.3  | 6.1           | 9.2  | 7.4         | 13.4 | 3.3   | 3.4  | 77.3               | 66.9 | 2.0               | 1.8  | 100                | 100  |
| Black                              | 1.5      | 2.6  | 2.6           | 5.7  | 5.5         | 11.9 | 4.5   | 4.1  | 81.2               | 71.8 | 4.6               | 3.9  | 100                | 100  |
| Hispanic                           | 1.3      | 2.4  | 2.3           | 5.0  | 1.8         | 12.2 | 2.1   | 2.4  | 86.6               | 74.9 | 6.0               | 3.1  | 100                | 100  |
| Asian & Pacific<br>Island American | 1.0      | 2.3  | 6.0           | 10.3 | 10.8        | 18.7 | 1.8   | 3.0  | 79.4               | 63.8 | 1.1               | 2.0  | 100                | 100  |
| American Indians                   | 3.4      | 6.4  | 3.6           | 14.2 | 4.3         | 8.4  | 6.0   | 4.7  | 81.0               | 65.3 | 1.8               | 1.0  | 100                | 100  |

\* This can be interpreted as follows: In 1973, 12.8 percent of all persons employed in the insurance industry were employed as managers.

<sup>a</sup> Includes only people working in life, accident, and health insurance firms and hospital and medical service plans (SIC 631 and 632).

<sup>b</sup> Percentages may not sum to 100 due to rounding.

Source: U.S. Equal Employment Opportunity Commission—Special Tabulations of EEO—1 Data.

**Table 2.4**  
**Hiring and Promotion Rates for Minorities and Women, 1974–80**

| Minority, sex, and occupation group<br>(no. of companies in sample) | 1974*<br>(169) | 1975<br>(164) | 1976<br>(178) | Year<br>1977<br>(189) | 1978<br>(167) | 1979<br>(191) | 1980<br>(176) |
|---|----------------|---------------|---------------|-----------------------|---------------|---------------|---------------|
| <i>Minorities</i>   |                |               |               |                       |               |               |               |
| No. hired   | 23,508         | 15,019        | 19,628        | 21,865                | 23,918        | 25,002        | 25,353        |
| Percent in  |                |               |               |                       |               |               |               |
| Officials/managers  | 0.3            | 0.5           | 0.7           | 1.9                   | 1.5           | 1.5           | 1.2           |
| Professionals   | 3.6            | 2.7           | 5.5           | 6.4                   | 6.5           | 5.1           | 6.3           |
| Technicians   | 2.7            | 2.9           | 3.8           | 5.2                   | 6.2           | 5.1           | 5.8           |
| Sales   | 21.1           | 34.6          | 23.7          | 21.2                  | 18.0          | 17.5          | 22.5          |
| Office/clerical   | 66.9           | 55.9          | 62.2          | 62.9                  | 64.8          | 65.0          | 60.8          |
| Labor/service worker  | 5.5            | 3.5           | 4.1           | 2.5                   | 3.0           | 4.1           | 3.2           |
| No. promoted  | 12,814         | 10,239        | 11,604        | 20,038                | 17,038        | 19,242        | 18,975        |
| Percent promoted to management, supervision, or professions         | 11.0           | 10.0          | 17.0          | 12.0                  | 15.0          | 14.0          | 15.2          |
| <i>Women</i>  |                |               |               |                       |               |               |               |
| No. hired   | 61,894         | 42,994        | 60,068        | 65,576                | 72,166        | 74,167        | 69,403        |
| Percent in  |                |               |               |                       |               |               |               |
| Officials/managers  | 0.4            | 0.4           | 0.5           | 1.4                   | 0.9           | 0.8           | 0.9           |
| Professionals   | 2.5            | 2.3           | 4.1           | 4.4                   | 4.3           | 5.0           | 5.2           |
| Technicians   | 2.6            | 2.9           | 3.4           | 4.4                   | 5.2           | 4.5           | 4.8           |
| Sales   | 3.0            | 5.6           | 4.8           | 4.8                   | 7.0           | 7.3           | 9.1           |
| Office/clerical   | 89.7           | 87.0          | 86.4          | 84.0                  | 81.8          | 80.9          | 78.5          |
| Laborer/service worker  | 1.9            | 1.8           | 0.9           | 1.0                   | 0.8           | 1.4           | 1.3           |
| No. promoted  | 47,827         | 39,190        | 44,180        | 55,776                | 66,679        | 75,451        | 69,834        |
| Percent promoted to management, supervision, or professions         | 12.0           | 9.0           | 12.0          | 22.0                  | 12.0          | 12.0          | 14.2          |

\* The Clearinghouse on Corporate Social Responsibility has also published hiring and promotion data for 1973, but the occupational categories differ from those used in subsequent years.

Source: Clearinghouse on Corporate Social Responsibility, *Social Reports of the Life and Health Insurance Business*, 1975–1981.

placed as officials and managers, the percentage brought into management positions remained very low. In 1980, 1.2 percent of minority "new hires" and less than 1 percent of female "new hires" were placed in management positions. Further, of women and minorities promoted during 1980, only 14 and 15 percent, respectively, were promoted to supervisory, professional, or management jobs. These percentages did not match peak promotion rates attained for women in 1977 (22 percent in supervisory, professional, or management positions) or minorities in 1976 (17 percent). In sales, where all women are substantially underrepresented, only about 9 percent of female "new hires" in 1980 were employed in this occupational category. This was only a slight improvement over previous years. Clearly, major changes in hiring and promotion patterns need to occur to achieve a more equitable representation of minorities and women in management, professional, and sales occupations in this decade.

### Training Opportunities

Better training opportunities would facilitate upward mobility.<sup>4</sup> Several professional and specialized educational institutions exist that provide training in insurance for employees currently employed by the industry. Upon completion of training, many of these institutions give examinations and issue professional certifications connoting a degree of expertise that prepares graduates for advancement. Among these organizations are the Society of Actuaries, the Life Underwriting Training Council, the American College, and the Life Office Management Association. All these organizations collect and maintain data on membership, enrollment, and graduates by

<sup>4</sup> Ibid., p. 19. Herbert S. Denenberg, "An Overview Report: Discrimination in the Insurance Marketplace and in the Insurance Business—With Primary Emphasis on Life, Health, Disability, and Pensions," in U.S., Commission on Civil Rights, *Discrimination Against Minorities and Women in Pensions and Health, Life, and Disability Insurance*, vol. 1 (1978), p. 275.

<sup>5</sup> Staff of Society of Actuaries, Chicago, Ill., telephone interview, Dec. 9, 1980; American College, telephone interview, Dec. 9, 1980; Loran Powell, president, Life Underwriting Training Council (LUTC), telephone interview, Dec. 31, 1980; Life Office Management Association, telephone interview, Dec. 9, 1980 (hereafter cited respectively as Society of Actuaries Interview, American College Interview, LUTC Interview, and Life Office Management Association Interview).

<sup>6</sup> The Society of Actuaries is an organization of people trained to use the principles of mathematical probability in establishing insurance premiums and claims reserves. American Council of Life Insurance, *1980 Life Insurance Fact Book* (Washington, D.C.), p. 116. (hereafter cited as *1980 Fact Book*).

<sup>7</sup> Ibid. Informally tabulated data show that 28 blacks are

sex but not by race or ethnic background.<sup>5</sup> Thus, it is difficult to determine the extent to which the industry is providing training for minorities that would prepare them for management and specialized professional positions where they are now substantially underrepresented. Such data should be collected so that the industry can fully assess its progress in providing employment opportunities. Data on work force composition and statistics on the hiring and promotion of minorities reported above suggest that participation in training programs is low.

The available data on training for women indicate that they are increasingly encouraged to avail themselves of educational opportunities but that much more needs to be done. The Society of Actuaries, for example, sponsors examinations in actuarial science that lead to the designations of fellow or associate in the society.<sup>6</sup> Although female representation in the society has doubled in less than 10 years, it remains low. In 1970, women constituted 2.5 percent of the society's membership.<sup>7</sup> By 1978, when membership totaled 6,165, about 6 percent were women.<sup>8</sup>

The Life Underwriting Training Council provides courses on sales training in life and health insurance to insurance agents.<sup>9</sup> In 1980 women students were 17.4 percent of the 28,161 enrollees and 2.3 percent of the 2,087 teachers.<sup>10</sup> The proportion of women who are enrollees is higher than the proportion currently occupying sales positions (see tables 2.3 and 2.4). This indicates the industry is trying to expand opportunities for women in sales.<sup>11</sup> However, much more needs to be done to raise their representation in this occupational category (less than 5 percent in 1978).

members of the Society of Actuaries or the American Academy of Actuaries, another professional association. Chairman of the Subcommittee on Minority Recruiting, Society of Actuaries, telephone interview, Kansas City, Mo., Dec. 11, 1980. The Subcommittee on Minority Recruiting also encourages minorities and women to become actuaries by awarding student scholarships for graduate study in actuarial science. Daniel F. Case, actuary, American Council of Life Insurance, letter to John Hope II, Acting Staff Director, U.S. Commission on Civil Rights, Dec. 23, 1981 (hereafter cited as Case Letter).

<sup>8</sup> Society of Actuaries Interview.

<sup>9</sup> *1980 Fact Book*, p. 115.

<sup>10</sup> LUTC Interview.

<sup>11</sup> The racial, ethnic, and sex composition of those taking courses offered by insurance training institutions is influenced not only by their outreach efforts but also by the affirmative action programs of insurance companies that, in their actions to hire and promote minorities and women, support and encourage participation in training.

The American College, an accredited institution of higher learning, offers studies leading to the award of the chartered life underwriter (CLU) diploma and professional designation.<sup>12</sup> This institution differs from other insurance training institutions in that a master of science degree can be obtained.<sup>13</sup> Since its inception in 1927, the American College has granted nearly 47,000 CLU designations, of which about 3 percent have been awarded to women.<sup>14</sup> In the past several years, however, representation of women in the CLU program has improved some—in the 1979 graduating class, 6.1 percent female, and the 1980 graduating class, 8.5 percent female.<sup>15</sup> Given the substantial underrepresentation of women among sales agents and underwriters, these gains still fall short of moving women into sales and underwriting in appreciable numbers.

Among other activities, the Life Office Management Association offers an eight-part educational program leading to the designation of fellow, Life Management Institute (FLMI).<sup>16</sup> Female enrollment in this program is generally high although it declines during the course of the program.<sup>17</sup> Enrollment in the first two parts of the program, which provide background in the principles of insurance, is about three-fourths female.<sup>18</sup> Most of the enrollees are clerks or persons beginning employment in the industry.<sup>19</sup> Women constitute about 45 percent of those who complete the entire program.<sup>20</sup>

These data show that some strides are being made in providing increased training opportunities, at least for women. If a more equitable representation of minorities and women is to be attained in management, sales, and the other professions within the reasonably near future, however, more emphasis needs to be placed on training, hiring, and promotion and on maintaining adequate data to measure progress.

<sup>12</sup> 1980 Fact Book, p. 116.

<sup>13</sup> Ibid.

<sup>14</sup> American College Interview.

<sup>15</sup> Ibid.

<sup>16</sup> Life Office Management Association Interview.

<sup>17</sup> Ibid.

<sup>18</sup> Ibid. This figure is only for spring 1978 new enrollees; it excludes students who failed to pass these parts the first time and are taking the courses again. Female representation in total spring 1978 enrollment for the remaining parts is as follows: part 3 (law), 62.2 percent female; part 4 (accounting), 58.0 percent; part 5 (finance and investment), 49.5 percent; part 6 (mathematics), 45.5 percent; part 7 (systems operations and data processing), 44.4 percent; part 8 (advanced management and specialized subjects), unknown. Ibid.

<sup>19</sup> Ibid.

Improvements in minority and female representation on boards of directors that set policy also are necessary. A 1979 study of board membership conducted by an executive search organization found that most insurance companies have some representation of minorities and women on their boards of directors.<sup>21</sup> Of the insurers participating in the study, over half had at least one woman board member; about one-third had at least one minority member.<sup>22</sup> Data were not presented in a way, however, that showed what proportion women and minorities constituted of board membership in companies where they were present. This latter measure is the better gauge of insurers' efforts to assure a voice for minorities and women in the policy decisions of boards of directors.

### **Effect of Government Programs on Minority and Female Employment**

A number of Federal, State, and local agencies have responsibilities that affect the equal employment opportunity activities of the insurance industry. These agencies include the Office of Federal Contract Compliance Programs in the U.S. Department of Labor, the Equal Employment Opportunity Commission, State and local fair employment practices commissions, and, to a certain degree, State insurance departments themselves.

#### **Office of Federal Contract Compliance Programs**

The Office of Federal Contract Compliance Programs (OFCCP) is responsible for enforcing Executive Order No. 11246.<sup>23</sup> This order requires employers who contract with the Federal Government to refrain from discrimination on the basis of race, color, religion, sex, or national origin in their

<sup>20</sup> Ibid. This figure is for the 1980 class. Women were 31.7 percent, 35.4 percent, and 39.7 percent, respectively, of the 1977, 1978, and 1979 classes. Thus, there has been a marked improvement in completion rates for women in recent years.

<sup>21</sup> The study was conducted by Korn/Ferry International. Separate data on the insurance industry, however, are only reported in "Study Shows Insurance Companies Ahead in Opening Boards to Women, Minorities," *National Underwriter*, Apr. 12, 1980, p. 17.

<sup>22</sup> Ibid. About 36 percent of all firms participating in the Korn/Ferry study, which included other than insurance companies, had at least one woman board member, and 19 percent had at least one minority member.

<sup>23</sup> 3 C.F.R. 339 (1965) reprinted in 42 U.S.C. §2000e at 1232 (1976).



employment practices and to take affirmative action to employ minorities and women.<sup>24</sup> Firms with 50 or more employees awarded contracts cumulating to \$50,000 or more annually are required to develop a written affirmative action plan.<sup>25</sup> The plan must identify areas in which minorities and women are underutilized in the contractor's work force and set goals and timetables to remedy any deficiencies.<sup>26</sup>

OFCCP can conduct compliance reviews of selected employers and has several enforcement tools available to assure compliance with the law. OFCCP can require employers to provide backpay to affected employees and to award retroactive seniority to correct deficiencies.<sup>27</sup> In fiscal year 1980, OFCCP targeted the insurance industry for special scrutiny, allocating 11 percent of its resources to conduct compliance reviews and to investigate employment practices among a number of insurance companies.<sup>28</sup> During the first half of the fiscal year, OFCCP completed 30 compliance reviews of insurers.<sup>29</sup> The investigations have generally revealed that minorities and women continue to be placed in low-paying positions, such as clerical jobs.<sup>30</sup>

Available information indicates that Federal contract compliance activities have not been vigorous enough to affect substantially employment in the insurance industry. As of 1978 few differences could be seen in the white-collar occupational distribution of minorities and women in contractor and noncontractor insurance firms. For example, among insurance companies that were noncontractors, 5.5 percent of all managers were minority men; among contractors, 3.8 percent of managers were minority men. Similarly, 2.0 percent of managers were minority women in noncontractor firms compared with

1.8 percent of all managers in companies with Federal contracts. (See table 2.5.)

Black and majority women, however, are significantly more heavily concentrated in technician jobs in contractor companies. In 1973, 59.6 percent of all technicians employed by contractors were women. By 1978 that figure had increased to 75 percent. In noncontractor insurance companies, 33.5 percent of technicians were women in 1973 and 48.2 percent were in 1978.<sup>31</sup>

Nonetheless, noncontractors have performed slightly better than contractors in placing minorities and women in professional and sales positions. As of 1978 women filled 43.8 percent and minority men 19.8 percent of professional and sales jobs in noncontractor firms. Among insurance companies with contractor status, the respective figures were 42.2 and 18.3 percent. These results raise questions about the vigor of Federal contract compliance enforcement in insurance during the last decade because more significant differences in occupational patterns might be expected between contractors and noncontractors, given affirmative action requirements with which contractors must comply.

### Equal Employment Opportunity Commission

The Equal Employment Opportunity Commission (EEOC) administers Title VII of the Civil Rights Act of 1964, which prohibits discrimination in employment on the basis of race, color, religion, sex, and national origin.<sup>32</sup> The EEOC receives and investigates job discrimination complaints. When it finds reasonable cause that the charges are justified, the EEOC attempts, through conciliation, to reach

other job titles such as mathematical aides. Equal Employment Opportunity Commission, *Equal Employment Opportunity Report: Minorities and Women in Private Industry* (September 1981). Available statistics indicate that the insurance industry has had a substantial pool from which to draw blacks and women with the necessary education. For example, among employed black men, 25 to 64 years old, 25.3 percent had some college education in 1979 compared with 43.1 percent of white men. Twenty-nine percent of black women had some college education compared with 35.8 percent of white women aged 25 to 64. Among Hispanic men in this age bracket, 21.3 percent had some college education compared with 20.6 percent of Hispanic women. U.S., Department of Commerce, *Educational Attainment in the United States*, March 1978 and 1979, Series P-20, no. 356 (August 1980), pp. 37-39.

<sup>32</sup> 42 U.S.C. §2000e-2 (1976).

<sup>24</sup> *Id.*

<sup>25</sup> 41 C.F.R. §60-2 (1980). Recently proposed rules would lower these thresholds to firms with 250 or more employees awarded a single contract of \$1 million or more. 46 Fed. Reg. 42,968, 42,992 (Aug. 25, 1981).

<sup>26</sup> *Id.*

<sup>27</sup> 41 C.F.R. §60-1.26 (1980). Retroactive seniority, while not expressly authorized, has been routinely awarded by OFCCP as one of the "appropriate remedies" authorized by this section.

<sup>28</sup> James W. Cisco, Division of Program Operations, OFCCP, interview in Washington, D.C., June 2, 1980.

<sup>29</sup> *Ibid.*

<sup>30</sup> *Ibid.*

<sup>31</sup> EEOC describes "technician" as an occupation requiring a combination of basic scientific knowledge and manual skill that can be obtained through 2 years of post-high school education. This position includes computer programmers and operators and

**TABLE 2.5**  
**Percentages of Women and Minorities in Key Insurance Industry Occupations by**  
**Federal Contractor Status: 1973 and 1978**

|                          | <b>CONTRACTORS</b>    |              |               |      |              |      |              |              |                    |              |
|--------------------------|-----------------------|--------------|---------------|------|--------------|------|--------------|--------------|--------------------|--------------|
|                          | Managers              |              | Professionals |      | Technicians  |      | Sales        |              | Office & clericals |              |
|                          | 1973                  | 1978         | 1973          | 1978 | 1973         | 1978 | 1973         | 1978         | 1973               | 1978         |
| <b>Men</b>               |                       |              |               |      |              |      |              |              |                    |              |
| Majority                 | 81.4*                 | 77.2         | 71.9          | 57.9 | 36.5         | 20.3 | 85.4         | 81.7         | 6.6                | 5.2          |
| Black                    | 1.4                   | 2.0          | 2.1           | 3.0  | 2.3          | 2.7  | 4.4          | 5.6          | 1.3                | 1.7          |
| Hispanic                 | 0.6                   | 1.0          | 0.7           | 1.1  | 0.9          | 1.0  | 1.8          | 2.4          | 0.5                | 0.5          |
| Asian & Pacific          |                       |              |               |      |              |      |              |              |                    |              |
| Island American          | 0.2                   | 0.6          | 0.8           | 1.1  | 0.7          | 0.9  | 0.5          | 1.4          | 0.3                | 0.3          |
| American Indian          | 0.1                   | 0.2          | <sup>b</sup>  | 0.1  | <sup>b</sup> | 0.2  | 0.1          | 0.2          | <sup>b</sup>       | <sup>b</sup> |
| <b>Women</b>             |                       |              |               |      |              |      |              |              |                    |              |
| Majority                 | 15.1                  | 17.2         | 22.6          | 31.7 | 51.0         | 60.2 | 6.6          | 7.0          | 73.4               | 74.0         |
| Black                    | 0.8                   | 1.3          | 1.2           | 3.4  | 5.9          | 10.3 | 0.8          | 1.2          | 13.0               | 16.0         |
| Hispanic                 | 0.2                   | 0.3          | 0.2           | 0.7  | 1.4          | 2.3  | 0.2          | 0.2          | 3.2                | 4.0          |
| Asian and Pacific        |                       |              |               |      |              |      |              |              |                    |              |
| Island American          | <sup>b</sup>          | 0.2          | 0.4           | 1.0  | 1.3          | 2.0  | <sup>b</sup> | 0.2          | 1.5                | 1.9          |
| American Indian          | <sup>b</sup>          | <sup>b</sup> | <sup>b</sup>  | 0.1  | <sup>b</sup> | 0.2  | <sup>b</sup> | 0.1          | 0.1                | 0.2          |
| <b>Total<sup>a</sup></b> | 100                   | 100          | 100           | 100  | 100          | 100  | 100          | 100          | 100                | 100          |
|                          | <b>NONCONTRACTORS</b> |              |               |      |              |      |              |              |                    |              |
| <b>Men</b>               |                       |              |               |      |              |      |              |              |                    |              |
| Majority                 | 86.3                  | 77.5         | 68.5          | 56.2 | 61.8         | 46.4 | 86.3         | 80.2         | 6.7                | 5.2          |
| Black                    | 3.7                   | 4.1          | 2.3           | 2.7  | 3.1          | 3.2  | 5.9          | 7.4          | 0.9                | 1.4          |
| Hispanic                 | 0.6                   | 0.9          | 0.6           | 0.9  | 0.9          | 1.2  | 1.6          | 1.9          | 0.2                | 0.3          |
| Asian & Pacific          |                       |              |               |      |              |      |              |              |                    |              |
| Island American          | 0.1                   | 0.3          | 0.6           | 0.7  | 0.6          | 0.9  | 0.2          | 0.4          | 0.1                | 0.2          |
| American Indian          | <sup>b</sup>          | 0.2          | 0.1           | 0.5  | <sup>b</sup> | 0.1  | <sup>b</sup> | 0.3          | <sup>b</sup>       | <sup>b</sup> |
| <b>Women</b>             |                       |              |               |      |              |      |              |              |                    |              |
| Majority                 | 8.5                   | 15.2         | 25.5          | 33.7 | 30.6         | 42.5 | 2.8          | 7.3          | 81.3               | 78.5         |
| Black                    | 0.6                   | 1.5          | 1.8           | 3.7  | 2.0          | 3.5  | 2.0          | 2.3          | 8.1                | 10.5         |
| Hispanic                 | <sup>b</sup>          | 0.2          | 0.3           | 0.7  | 0.4          | 1.2  | <sup>b</sup> | 0.1          | 1.8                | 2.3          |
| Asian & Pacific          |                       |              |               |      |              |      |              |              |                    |              |
| Island American          | <sup>b</sup>          | 0.2          | 0.3           | 0.5  | 0.5          | 0.9  | <sup>b</sup> | 0.1          | 0.7                | 1.1          |
| American Indian          | <sup>b</sup>          | 0.1          | <sup>b</sup>  | 0.5  | <sup>b</sup> | 0.1  | <sup>b</sup> | <sup>b</sup> | 0.1                | 0.5          |
| <b>Total<sup>a</sup></b> | 100                   | 100          | 100           | 100  | 100          | 100  | 100          | 100          | 100                | 100          |

<sup>a</sup> Percentages may not sum to 100 due to rounding.

<sup>b</sup> Less than 0.1 percent of all employees in the occupation specified.

\* This can be interpreted as follows: In 1973, 81.4 percent of the managers in insurance firms that have Federal contracts were majority men.

Note: Includes only people working in life, accident, and health insurance firms and hospital and medical service plans (SIC 631 and 632).

Source: U.S. Equal Employment Opportunity Commission—Special Tabulations of EEO-1 data.

an agreement eliminating all aspects of discrimination revealed by the investigation.<sup>33</sup> If conciliation fails, EEOC is empowered to go to court to enforce compliance.<sup>34</sup>

The EEOC also serves a data collection and analysis function. Every private employer subject to Title VII with 100 or more employees is required to submit an EEO-1 report.<sup>35</sup> These reports are designed to collect information on the race, national origin, and sex of employees in nine major occupational categories.<sup>36</sup>

The EEOC is also responsible for enforcement of the Equal Pay Act, which forbids compensation differentials based on sex.<sup>37</sup> A study conducted by the U.S. Bureau of Labor Statistics in 1976 indicates that some wage discrimination based on sex is occurring in the insurance industry.<sup>38</sup> The study found that men predominate in most of the relatively high-paying professional occupations, such as actuaries, underwriters, computer programmers, and systems analysts.<sup>39</sup> In 1976 average salaries for these jobs typically fell between \$250 and \$350 per week.<sup>40</sup>

Women, on the other hand, made up almost all workers in the general clerical occupations where salaries averaged about \$175 per week.<sup>41</sup> After taking into account differences in occupational distribution affecting wage levels, the study found that a 10 percent differential in male-female salaries persisted.<sup>42</sup>

### State and Local Fair Employment Practices Commissions

In States and localities that have their own laws prohibiting discriminatory employment practices, complainants may also seek relief from fair employment practices agencies. In fact, complaint charges often must be filed first with these agencies before

turning to the EEOC.<sup>43</sup> Nearly all States and many local jurisdictions have fair employment agencies.<sup>44</sup>

Employers are forbidden to discriminate in such personnel practices as hiring, promotion, compensation, and dismissal.<sup>45</sup> In some respects, these State laws tend to be more stringent than Federal law. For example, in some States an employer need have only one or more employees to be affected by State law, while Title VII only reaches employers with 15 or more employees.<sup>46</sup> Where insurance companies hold a contract with a State or local government entity, they may also be expected to meet affirmative action obligations like those imposed by OFCCP.<sup>47</sup> Thus, the compensation differentials, occupational distributions, participation rates, and hiring and promotion patterns discussed above reflect not only the effect of the Federal Government but of State agencies as well.

### State Insurance Departments

Although a number of Federal, State, and local equal employment opportunity agencies clearly have jurisdiction over the employment practices of insurance companies, the role of State insurance departments is not well defined. Among State insurance departments represented at the Commission on Civil Rights insurance consultation in April 1978, some have concluded that they do not have authority in this area, others have not considered the question, and still others have decided that they do have some authority over the employment practices of insurers.<sup>48</sup> In Pennsylvania, one of the few States officially to determine its jurisdiction, the insurance commissioner has obtained a State attorney general's opinion that the insurance department can refuse to issue or renew licenses to and revoke or suspend licenses of companies or agencies that discriminate

<sup>33</sup> 42 U.S.C. §2000e-4(g)(4)(1976).

<sup>34</sup> 42 U.S.C. §2000e-5(f)(1)(1976).

<sup>35</sup> 29 C.F.R. §1602.7 (1981). There are approximately 680 life insurance companies and medical service plans that have 100 or more employees. U.S., Department of Commerce, Bureau of the Census, *County Business Patterns—United States* (1979), p. 73.

<sup>36</sup> EEOC Form 100, "Employer Information Report EEO-1." Because the nine occupational categories are comprised of many more narrowly defined job classifications, the use of just nine categories may obscure segregation of minorities and women occurring within the nine broad occupations.

<sup>37</sup> *Ibid.* 29 U.S.C. §206(d)(1976). Title VII of the Civil Rights Act of 1964 also forbids compensation differences based on sex, as well as race, national origin, and religion. 42 U.S.C. §2000e-2(a)(1)(1976).

<sup>38</sup> U.S., Department of Labor, Bureau of Labor Statistics, *Industry Wage Surveys: Banking and Life Insurance* (December

1976). This study did not gather data on the race or national origin of employees.

<sup>39</sup> *Ibid.*, pp. 91-101.

<sup>40</sup> *Ibid.*

<sup>41</sup> *Ibid.*

<sup>42</sup> *Ibid.*, p. 92. The analysis also controlled for regional wage variations but not for differences in wage level among establishments. Other factors controlled for included certain establishment practices, such as shift differential supplementary wage benefits and pay differences based on seniority.

<sup>43</sup> 42 U.S.C. §2000e-8(b)(1976).

<sup>44</sup> 8A FEP Manual (BNA) 453, 455, 457.

<sup>45</sup> *Id.*

<sup>46</sup> See 6 Labor Policy and Practice BNA ¶451:1, at 45.

<sup>47</sup> *Id.*, ¶451:5, at 49.

<sup>48</sup> Remarks by State insurance officials, *Consultation*, vol. 1, pp. 205-10.

on the basis of race, color, religion, sex, or national origin in their employment policies.<sup>49</sup>

Although all State insurance departments may not have broad fair employment enforcement authority, all do carry the responsibility of licensing agents. With few exceptions, however, insurance departments do not collect or analyze data on the sex, race, or national origin of agents licensed to conduct business in the State. Each State has agent qualification and licensing statutes that define illegal or unethical conduct and grant regulators the statutory authority to monitor and punish discriminatory actions by agents and brokers.<sup>50</sup> In addition, insurance departments usually prescribe or approve study materials and develop examinations used in testing the knowledge of agent applicants and, in this way, strive to assure that only qualified agents with knowledge of unfair discrimination practices be allowed to sell insurance.<sup>51</sup>

Some evidence exists that agent licensing tests may be discriminatory against minorities. A suit filed by the Golden Rule Insurance Company (Ill.) against the Illinois insurance director and the Educational Testing Service (ETS)<sup>52</sup> alleges that the agent licensing examination prepared by ETS has had a substantial discriminatory impact, as measured by the different passing rates for whites and blacks.<sup>53</sup> About 55 percent of whites and 40 percent of blacks passed the ETS test in Illinois before it was revised in 1977.<sup>54</sup> After the revisions, the passing rates were 77 percent for whites and 52 percent for blacks.<sup>55</sup> Although passing rates rose for both groups, the black-white differential widened. Golden Rule Insurance Company alleges that the test is unfair because it covers subject areas unlikely to be

encountered by a beginning agent or broker, it requires a high level of test-taking ability and of linguistic and vocabulary skills unrelated to an agent's competency or trustworthiness, and it has not been validated as measuring job-related skills in accordance with Equal Employment Opportunity Commission requirements.<sup>56</sup> Since no agent can do business without a license, test results such as these significantly affect the ability of insurance companies to employ minorities.

Another area of controversy surrounding State licensing examinations concerns the use of English-only language tests. Recent decisions by the Equal Employment Opportunity Commission have determined that the use of English-only examinations constitutes unlawful employment discrimination based on national origin. Hispanics were noted as being particularly adversely affected.<sup>57</sup>

In summary, State licensing activities do not in all circumstances facilitate the entry of minorities into sales. Further, for lack of data collection, States remain unaware of the effect their licensing function has on employment of minorities as well as of women. Given the especially low representation of women in sales, lack of adequate State insurance oversight is compounding an already serious problem that Federal and State civil rights agencies are not adequately addressing either. The problem extends beyond sales, however, into management and professional positions where minorities and women are also underrepresented. It is at this level that company policies and practices are established and the contribution of these groups becomes especially important.

<sup>49</sup> William J. Sheppard, Pennsylvania Insurance Commissioner, letter to Arthur S. Flemming, Chairman, U.S. Commission on Civil Rights, May 18, 1978, reprinted in *Consultation*, vol. 2, p. 1078.

<sup>50</sup> Davis W. Gregg and Vane B. Lucas, ed., *Life and Health Insurance Handbook* (Homewood, Ill.: Richard D. Irwin, Inc., 1973), pp. 942-43.

<sup>51</sup> *Ibid.*, p. 943.

<sup>52</sup> ETS provides several States with examinations that insurance agents and brokers must pass to obtain a license. *Golden Rule Life Insurance Company v. Illinois Insurance Director and Educational Testing Service*, 86 Ill. App. 3d 323, 408 N.E.2d 310 (1980). Illinois was the first State to adopt the ETS tests. The examination has also been adopted by Arizona, Colorado, Delaware, Indiana, Maryland, Massachusetts, Nevada, New York, Pennsylvania, and Wisconsin. *National Underwriter*, Aug. 14, 1976, p. 1.

<sup>53</sup> *Golden Rule Life Insurance Company v. Illinois Insurance Director and Educational Testing Service*, 86 Ill. App. 3d 323, 408 N.E.2d 310 (1980).

<sup>54</sup> "Illinois Insurer Pursues Fight to End 'Bias' in Testing Agent Candidates," *National Underwriter*, Apr. 1, 1978, pp. 6-7; "Agents Testing Battle Revived in Illinois," *National Underwriter*, Aug. 2, 1980, pp. 6-7.

<sup>55</sup> *Ibid.*

<sup>56</sup> *Golden Rule Life Insurance Company v. Illinois Insurance Director and Educational Testing Service*, 86 Ill. App. 3d 323, 408 N.E.2d 310 (1980). The appellate court has ruled that these complaints are sufficient to state a cause of action for alleged violation of due process and has remanded the case to lower court for trial.

<sup>57</sup> EEOC Decision No. 75-249 (May 6, 1975) [1975] Empl. Prac. Dec. (CCH) ¶6457; EEOC Decision No. 75-252 (May 13, 1975), [1975] Empl. Prac. Dec. (CCH) ¶6458.

## Health Insurance Coverage of Minorities and Women

The employment patterns described in the previous chapter and the health insurance coverage rates presented here share certain common features. Both employment and the provision of health insurance are integral and economically important aspects of the industry. In both instances, minorities and women do not enjoy the economic benefits of participation to the extent majority men do.

For those seeking insurance, certain socioeconomic factors are associated with ability to obtain coverage. For example, participation in the labor force is a significant vehicle through which health insurance is acquired, since approximately 90 percent of insurance is obtained through the workplace.<sup>1</sup> Health insurance coverage rates also vary by income and type of job as a consequence of underwriting practices that lead insurers to avoid those who may not be able to maintain premiums or who are not good risks. Similarly, because of the predominance of group insurance, many persons obtain health coverage through another family member who stands as the primary insured. Thus,

individual and family characteristics such as age, marital status, and family relationship have a significant bearing on health insurance coverage. In addition, people with health limitations, because they represent a greater degree of risk, often find it difficult, if not impossible, to obtain insurance. To the extent that minorities and women disproportionately possess those health and socioeconomic characteristics adversely affecting insurance coverage rates, they are necessarily less likely to have insurance than majority men.

Still other reasons were indicated by participants in the Commission's 1978 consultation. For example, participants noted that the insurance industry has not always given minorities and women the marketing attention directed toward majority men.<sup>2</sup> Others remarked that the industry is by nature conservative, slow to change, and not always in possession of the information necessary to assess accurately insurability of groups with which it has little experience.<sup>3</sup> Thus, just as minorities and women are underrepresented in management and decisionmaking positions

<sup>1</sup> Health Insurance Institute, *1980-1981 Source Book of Health Insurance Data* (Washington, D.C.: Health Insurance Association of America), p. 29 (hereafter cited as Source Book).

<sup>2</sup> Herbert S. Denenberg, "An Overview Report: Discrimination in the Insurance Marketplace and in the Insurance Business—With Primary Emphasis on Life, Disability, and Pensions," in U.S., Commission on Civil Rights, *Discrimination Against Minorities and Women in Pensions and Health, Life, and Disability Insurance*, vol. 1 (1978), pp. 266-69, 273-74. Naierman and Brannon, "Sex Discrimination in Insurance," *Ibid.*, pp. 480-83; Vecchio and Cerda, "Discrimination Against Farmworkers in the

Insurance Industry," *Ibid.*, pp. 519-26; Randall, "Risk Classification and Actuarial Tables," *Ibid.*, pp. 537-38, 541-42, 550-61, 607-8; Lamel, "State Regulation of the Insurance Industry," *Ibid.*, pp. 677-88; Sheppard and Lewis-Carter, "Discrimination in the Insurance Marketplace: A Pennsylvania Overview," *Ibid.*, pp. 707-19; and Alderete, "Comments," *Ibid.*, p. 750.

<sup>3</sup> Denenberg, "Overview Report," *Ibid.*, pp. 257-59, 261-62, 265, 269-71, 277-79; Vecchio and Cerda, "Discrimination Against Farmworkers in the Insurance Industry," *Ibid.*, pp. 520-22; and Remarks by Cruz Alderete, *Ibid.*, pp. 240 and 246.

in the industry, so also are many less likely to have health insurance.

According to available statistics, the vast majority of Americans under 65 years of age have some form of health insurance coverage. In 1976, approximately 87 to 88 percent of the population under 65 years of age was covered by public or private health insurance.<sup>4</sup> As the data presented in figure 3.1 show, however, health insurance protection is not equally shared by all members of society. While 9 out of 10 majority persons aged 14 to 64 had some form of health insurance coverage in 1976, coverage rates for minorities were considerably lower. Fewer than 3 out of 4 Hispanics and fewer than 7 out of 10 American Indians were covered. Approximately 8 in 10 blacks and Asian and Pacific Island Americans had some form of health insurance. Although black, Asian and Pacific Island American, and American Indian women had significantly higher insurance coverage rates than men of the same race or ethnicity, these minority women and Hispanic women were still less likely to be covered than majority women.

These overall figures, however, do not reveal some important factors associated with differences in health insurance coverage between majority men, women, and minorities. To help explain the effect of these factors, the following analysis describes differential rates of insurance coverage for majority males, minorities, and women, holding constant a single explanatory factor. Insurance underwriting and marketing practices guided the choice of explan-

atory variables. The variables are grouped into three areas of analysis: employment and income; marital status, age, and family relationship; and health condition.<sup>5</sup>

The Survey of Income and Education (SIE), conducted by the Bureau of the Census in 1976, is the primary source of data for the analysis. One advantage of this survey is that the sample is large enough (approximately 150,000 households) to show health insurance coverage rates for blacks, Hispanics, Asian and Pacific Island Americans, and American Indians by sex.<sup>6</sup> The SIE is the largest, most recent survey to include a question on whether or not a person is covered by health insurance,<sup>7</sup> as well as comprehensive information on income and employment characteristics.

Because this chapter focuses on differential rates of insurance coverage made available through non-public sources, the SIE data have been adjusted to exclude people who are covered by or most likely to be eligible for public health insurance or health care assistance. Thus, persons who reported having medicaid coverage as well as those enrolled in local or Federal public assistance programs have been deleted from the data base used to derive the coverage rates reported in this chapter. (See appendix A for a full explanation of methodology.)

Some people who would appear to be eligible for medicaid, such as those with an income of under \$3,000 a year, however, are included, because they are not eligible under present public assistance regulations.<sup>8</sup> Nevertheless, given the assumptions

<sup>4</sup> See appendix A for a discussion of various estimates of the uncovered population.

<sup>5</sup> Given the size of the sample survey used for this analysis (the Survey of Income and Education) and the information available from the survey, it was impossible to control simultaneously for all factors affecting the degree of insurance coverage. Most particularly, the SIE data lack an adequate health status variable. Health status of the individual is clearly an important determinant of need for insurance as well as the ability to acquire health insurance, given present medical underwriting standards. Multivariate analysis would provide the basis for more definitive statements about the extent to which differences in socioeconomic status and health condition are associated with disparities in health insurance coverage. Forthcoming data from the National Medical Care Expenditure Survey, sponsored jointly by the National Center for Health Statistics and the National Center for Health Services Research, Department of Health and Human Services, may provide a better vehicle for such analysis.

In addition, in the present univariate analysis, level of educational attainment is not included as a separate explanatory variable, since it is highly correlated with income and occupation, factors that have a more direct bearing on one's ability to acquire health insurance.

<sup>6</sup> Due to the relatively small size of the Asian and Pacific Island American and the American Indian population samples relative to other groups, statistics describing insurance coverage rates for these individuals are more likely to be unavailable or subject to greater sampling variability than those presented for blacks, Hispanics, or members of the majority.

<sup>7</sup> The SIE health insurance question determined if an individual was covered by a health insurance plan or other program that provided benefits or services. A person was listed as insured whether covered in his or her own name or under a policy held by someone else who stood as the primary insured. Further, the interviewer determined if the coverage was: (a) through an employer group plan, (b) through a union group plan, (c) by an individual plan, (d) by medicare, (e) by medicaid, (f) Veterans Administration for service disability, (g) by CHAMPUS (Comprehensive Health and Medical Plan for Uniformed Services) or on-base military care, (h) through some other private source, or (i) don't know source. A single individual could have any number of plans marked "yes." The SIE data presented in this chapter make no distinction between persons covered by group or nongroup plans.

<sup>8</sup> Federal law limits coverage under medicaid to those persons

made in omitting persons possibly eligible for medicaid and the complexity of State medicaid eligibility requirements, some persons eligible for public health care programs may not have been deleted.

## Employment and Income

Because most people acquire coverage through the workplace, the degree and nature of an individual's involvement in the labor force is perhaps the most important socioeconomic factor affecting the acquisition of health insurance. In 1978, 82.3 percent of health insurance premiums purchased group policies, and 17.6 percent bought individual or family policies.<sup>9</sup> Thus, an examination of employment-related characteristics such as labor force participation, occupation, and industry is central to understanding the relationship of employment and health insurance because such factors are taken into account in insurance underwriting and marketing.<sup>10</sup> An examination of insurance coverage rates by income level is also warranted because income is associated with the type of job a person has (if any) and the employment-related benefits received, in-

who fit into one of the categories covered under the cash welfare programs. 42 U.S.C. §1396a (1976 & Supp. III 1979). These categorical requirements result in the exclusion of low-income persons from program coverage regardless of their income. These include single persons and childless couples. Also excluded are intact families unless one parent is incapacitated or the family is receiving assistance in one of the 30 States and jurisdictions that extend AFDC coverage to families of jobless and partially employed fathers. Staff of Senate Committee on Finance, "Background Material Related to Health Benefits for Low-Income Persons," 96th Cong., 2d sess. (Mar. 19, 1980) (unpublished).

<sup>9</sup> *Source Book*, p. 30.

<sup>10</sup> O.D. Dickerson, *Health Insurance* (Homewood, Ill.: Richard D. Irwin, Inc., 1968), pp. 551-54. Davis W. Gregg and Vane B. Lucas, ed., *Life and Insurance Handbook* (Homewood, Ill.: Richard D. Irwin, Inc., 1973), pp. 341-42 and 435-38.

<sup>11</sup> Denenberg, "Overview Report," *Consultation*, pp. 268, 276-78; Dickerson, *Health Insurance*, pp. 551-53; Gregg and Lucas, *Handbook*, pp. 341-42, 435-36. Income is not as important a factor, however, in health insurance as in life and disability income insurance and pensions. In these latter forms of insurance, benefits are often either some fraction or multiple of earnings or income. Gregg and Lucas, *Handbook*, pp. 202-3, 343-44, 442-44, 531-34.

<sup>12</sup> U.S., Commission on Civil Rights, *Affirmative Action in the 1980s: Dismantling the Process of Discrimination* (1981), pp. 8-14.

<sup>13</sup> See note 7, chap. 1.

<sup>14</sup> See U.S., Commission on Civil Rights, *Social Indicators of Equality for Minorities and Women* (August 1981), chaps. 3 and 4, for an analysis of the economic status of minorities and women relative to majority men. Unemployment rates are discussed specifically on pp. 28-34. There are several proposed explanations for differences in the unemployment rates of majority men, minorities, and women: employer discrimination, the occupational segregation of minorities and women in high-turnover jobs, and the discontinuous labor force participation of women due to

cluding health insurance. Income also reflects, more directly, the capacity to purchase an individual policy when work-related insurance benefits are not provided or when poor health conditions result in high premium costs. In addition, as the insurance industry is concerned with profitmaking and the selection of low-risk insureds, some industry marketing and underwriting practices implicitly or explicitly take income into account.<sup>11</sup> However, because of past and present discrimination that denies equal employment opportunity, the close relationship between employment and the acquisition of health insurance contributes to creating a barrier against adequate insurance coverage for many women and racial and ethnic minorities.<sup>12</sup> Compared with white males,<sup>13</sup> women, as well as blacks, Hispanics, and other racial and ethnic minorities, are more likely to be unemployed,<sup>14</sup> to be employed on a part-time basis,<sup>15</sup> or to hold low-paying or seasonal jobs.<sup>16</sup> Further, minorities and women are more likely to be employed in industries considered to be poor risks

child-care responsibilities. See Ray Marshall, "The Economics of Racial Discrimination: A Survey," *Journal of Economic Literature*, September 1974, pp. 849-71. Also Nancy S. Barrett and Richard D. Morgenstern, *Why Do Blacks and Women Have High Unemployment Rates* (National Technical Information Service, no. PB 236670: 1974), and Beth Niemi, "Geographic Immobility and Labor Force Mobility: A Study of Female Unemployment," in *Sex, Discrimination, and the Division of Labor*, ed. Cynthia B. Lloyd (New York: Columbia University Press, 1975), pp. 61-89.

<sup>15</sup> In 1975 approximately 13.4 percent of all white men who worked during the year were employed on a part-time basis. In contrast, 33.6 percent of white women, 27.5 percent of black women, 25.8 percent of Hispanic women, and 15.1 percent of black men who worked during the year were employed part time. Only Hispanic men (11.7 percent of whom worked part time) were less likely than white men to be employed on a part-time basis. U.S., Department of Commerce, Bureau of the Census, *Money Income and Poverty Status in 1975 of Families and Persons in the United States and the West Region, by Divisions and States*, Current Population Reports, series P-60, no. 113 (July 1978), table 1B, pp. 15, 16, 21, 22, 27, and 28 (hereafter cited as *Money Income*).

<sup>16</sup> As an example, 21.7 percent of white men who worked during 1975 were employed in occupations where workers had a median income of less than \$5,000. These occupations included laborers (nonfarm), service workers, and farm workers. By contrast, 38.2 percent of black men who worked during 1975 were employed in such occupations. *Money Income*, table 1B, pp. 15 and 21. Also, among nonwhite men who were out of the labor force during the third quarter of 1980 but who had worked at some job during the previous 12 months, 28.0 percent had left their job because it was seasonal or temporary employment or there was insufficient work. Among their white male counterparts, 17.8 percent left their jobs for the same reasons. U.S., Department of Labor, *Employment and Earnings*, vol. 27 (October 1980), p. 67, table A-57.

**FIGURE 3.1**

**Percentage of Persons 14 to 64 Years Old with Health Insurance Coverage, by Race or Ethnicity and Sex: 1976.**

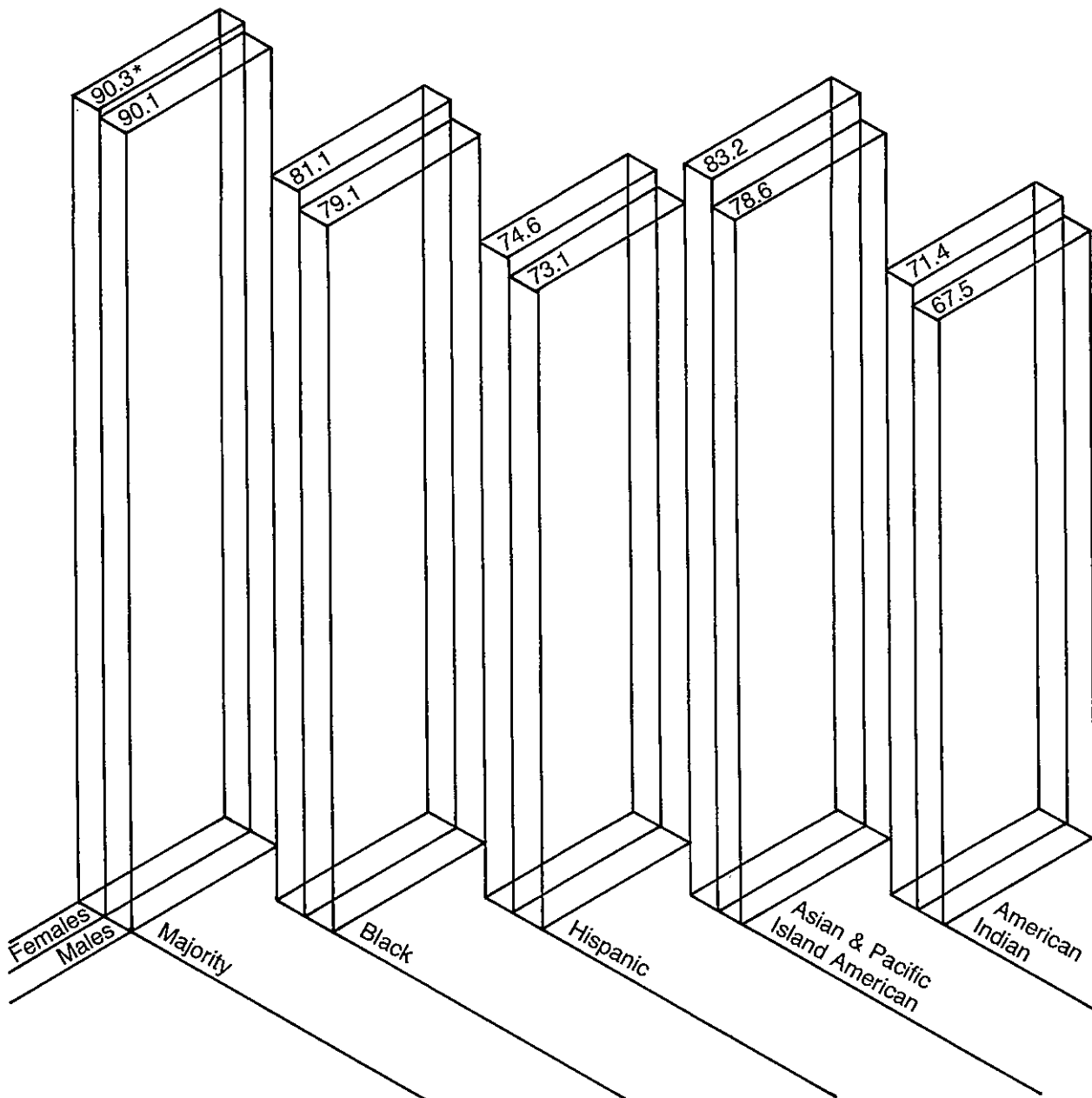

Note: Excludes persons covered by medicaid or medicare, receiving supplemental security income (SSI), public assistance, or welfare payments. See appendix A.

\* The difference between this value and the corresponding value for majority men is not statistically significant at the 0.05 level of confidence. See appendix A for data source and sampling information.

Source: Special tabulations from the Survey of Income and Education, 1976.



by the insurance industry, such as agriculture and private household services, respectively.<sup>17</sup>

### Employment Status

As shown in table 3.1, employed persons of all ethnic and racial groups have higher rates of insurance coverage than persons who are not employed. Employed majority members, however, are more likely to have health insurance coverage than employed minorities. In contrast, virtually no difference exists in the health insurance coverage rates of employed majority men and women; approximately 92 percent of both sexes have some form of coverage. Employed minority women, however, are somewhat more likely to have health insurance than employed minority men.<sup>18</sup> Of all employed persons, Hispanics and American Indians are the least likely to have insurance coverage; over 20 percent of persons in both groups lack insurance coverage. As these figures show, being employed offers no guarantee of health insurance coverage, especially for minorities. Although most employed minorities have health insurance, disparities in coverage between minority and majority employees remain.

Because health insurance coverage is frequently obtained through employment, unemployment presents a major obstacle to coverage. Several factors affect health insurance coverage rates for the unemployed. One is access to coverage under policies of other family members.<sup>19</sup> A second is the availability of continued coverage under a group

policy during a period of layoff.<sup>20</sup> Another is the degree to which financial resources are available to replace group coverage with an individual policy. Because individual insurance premiums purchase fewer benefits than group insurance and because in individual coverage an employer no longer shares premium expenses, the cost of an individual policy comparable to previous group coverage may be prohibitive.<sup>21</sup> In fact, no more than 10 to 14 percent of unemployed workers losing group health insurance substitute individual health insurance.<sup>22</sup>

As table 3.1 shows, the unemployed generally have the lowest rates of health insurance coverage.<sup>23</sup>

Nonetheless, unemployed minority women lack health insurance to a greater degree than unemployed majority women. A much greater discrepancy exists, however, between unemployed majority and minority men. Approximately two-thirds (67 percent) of unemployed majority men have health insurance. In comparison, 54 percent of unemployed black men, approximately 42 percent of unemployed Hispanic and Asian and Pacific Island American men, and only 28 percent of unemployed American Indian men are covered. These conditions clearly suggest loss of health insurance as an overlooked but significant cost of unemployment for minority men, which can be particularly devastating during a recessionary period.<sup>24</sup>

<sup>17</sup> Vecchio and Cerda, "Discrimination Against Farmworkers in the Insurance Industry," *Consultation*, vol. 1, pp. 519-26. See also Dickerson, *Health Insurance*, p. 552, and appendix table B.2.

<sup>18</sup> The higher insurance rates for minority women are due, in part, to the fact that they are employed in those occupations and industries with high coverage rates (see appendix tables B.1 and B.2). In addition, women may be more likely to have access to insurance through their husbands' policy than men through their wives' insurance. The insurance coverage rate for employed Asian and Pacific Island American women (86.4), however, is not significantly higher than that for Asian and Pacific Island American men (84.4), at the 0.05 level of statistical confidence.

<sup>19</sup> U.S., Congress, Congressional Budget Office, *Profile of Health Care Coverage: The Haves and Have-Nots* (March 1979), p. 20 (hereafter cited as *Haves and Have-Nots*).

<sup>20</sup> Available data indicate that continuation of coverage benefits is more readily available under union negotiated plans than non-union-negotiated plans. As of 1974, 55 percent of workers in union-negotiated health plans had health care protection during layoffs while 20 percent of the workers in nonnegotiated plans had coverage. Benefits were also provided for a longer period of unemployment by negotiated plans than by nonnegotiated plans. Daniel N. Price, "Health Benefits for Laidoff Workers," *Social Security Bulletin*, vol. 39, no. 2 (February 1976), p. 43.

<sup>21</sup> Among respondents to the 1976 Health Interview Survey who indicated they had no health insurance, about half of majority persons said they had no insurance because the premiums were too expensive. In contrast, about 70 percent of blacks and two-thirds of Hispanics had no health insurance because the premiums were beyond their financial means. Special tabulations from the 1976 Health Interview Survey.

<sup>22</sup> A. James Lee, Abt Associates, "Health Insurance Loss Due to Unemployment: Descriptive and Behavioral Analyses," *Effects of the 1974-75 Recession on Health Care for the Disadvantaged*, U.S., Department of Health, Education, and Welfare, National Center for Health Services Research, Research Summary Series, (PHS) 79-3248 (January 1980), p. 38.

<sup>23</sup> Statistically, unemployed black and American Indian women do not experience significantly lower insurance coverage rates than women who are not in the labor force, at the 0.05 level of confidence.

<sup>24</sup> Related factors may account for the substantial loss of health insurance coverage of minority men during unemployment. They may have less access to continued coverage through their group policy during layoff periods or through their spouse's policy. Further, the higher incidence of health limitation among minorities may preclude them from getting an individual replacement policy. (See ch. 3 "Income," and "Family Characteristics.")

**TABLE 3.1****Percentage of Persons 14 to 64 Years Old with Health Insurance Coverage, by Employment Status, Race or Ethnicity, and Sex: 1976**

| Race or ethnicity and sex       | Employment status  |          |            |                                 |
|---------------------------------|--------------------|----------|------------|---------------------------------|
|                                 | Total <sup>a</sup> | Employed | Unemployed | Not in labor force <sup>b</sup> |
| Majority                        |                    |          |            |                                 |
| Males                           | 90.1               | 91.8     | 66.9       | 86.9                            |
| Females                         | 90.3*              | 92.0*    | 77.6       | 89.5                            |
| Black                           |                    |          |            |                                 |
| Males                           | 79.1               | 85.1     | 54.4       | 68.2                            |
| Females                         | 81.1               | 88.1     | 69.8*      | 72.3                            |
| Hispanic                        |                    |          |            |                                 |
| Males                           | 73.1               | 77.9     | 42.4       | 60.8                            |
| Females                         | 74.6               | 81.1     | 64.0*      | 69.7                            |
| Asian & Pacific Island American |                    |          |            |                                 |
| Males                           | 78.6               | 84.4     | 41.4       | 62.1                            |
| Females                         | 83.2               | 86.4     | 63.0*      | 79.9                            |
| American Indian                 |                    |          |            |                                 |
| Males                           | 67.5               | 74.4     | 28.3       | 45.5                            |
| Females                         | 71.4               | 79.6     | 61.9*      | 63.3                            |

<sup>a</sup> Excludes persons covered by medicaid or medicare, receiving supplemental security income (SSI), public assistance, or welfare payments. See appendix A.

<sup>b</sup> Persons "not in the labor force" include those who are not classified as employed or unemployed (looking for work). This category includes persons engaged in own home housework, in school, unable to work, the voluntarily idle, and those seasonal workers who are not employed or looking for work.

\* The difference between this value and the corresponding value for majority males is not statistically significant at the 0.05 level of confidence. See appendix A for data source and sampling information.

Source: Special tabulations from the Survey of Income and Education, 1976.

## Occupation

Because health insurance is usually acquired through an employer and because insurance companies consider job characteristics in underwriting and marketing, an individual's occupation and industry are significant determinants of health insurance availability.<sup>25</sup> As shown in table 3.2, the overall difference in insurance coverage between majority and minority workers is generally reduced when workers with the same occupation are compared. However, within the same occupation, most minority workers continue to have significantly lower insurance coverage rates when compared with majority men. These disparities point to potential minority markets the industry is overlooking.

Except for black transport equipment operatives, in no occupational categories do black, Hispanic, or American Indian men have insurance coverage rates that equal or exceed the health insurance coverage rates of majority men.<sup>26</sup> Within nonagricultural occupations, differences in health insurance coverage rates between black and majority men are greatest for professionals, managers, and sales workers. Hispanic men, relative to majority men, are considerably less likely to be covered in crafts, operative, and service jobs. Among farm laborers, black and Hispanic men are substantially less likely to have health insurance than their majority counterparts. Although farm laborers are a small percentage of the employed, the effect of these coverage rates is greatest for black and Hispanic men, as they are disproportionately represented among farm laborers.<sup>27</sup>

As shown in table 3.2, minority women are also less likely to have health insurance coverage than majority men in sales, operative (excluding trans-

port), and service occupations.<sup>28</sup> For Hispanic women, however, this is true regardless of occupation. There are also large differences in coverage rates between majority and minority female private household workers. While five in six (83 percent) majority household workers have some form of insurance, only two-thirds of black female household workers and less than half of all female Hispanic workers are insured.<sup>29</sup> The fact that female private household workers have low rates of insurance coverage relative to women in other occupations has a disproportionate effect on minority women, as they are overrepresented in this occupation.<sup>30</sup>

## Industry

The particular industry of employment is also associated with an individual's chances of having health insurance. Generally, high levels of insurance coverage characterize the following industries: manufacturing, transportation, communication, public utilities, wholesale trade, finance, insurance, real estate, professional services, and public administration. However, in most comparisons of majority male and minority workers within these industries (excluding finance, insurance, and real estate), majority males are more likely to have health insurance. These data are shown in table 3.3. For example, in the highly unionized transportation, communication, and public utilities industries, approximately 88 percent of black and Hispanic men have health insurance compared with 94 percent of majority men.

The industries in which minority workers generally fare least well relative to majority men are

workers is not significantly lower than that for similarly employed majority males, at the 0.05 level of statistical confidence.

<sup>25</sup> It should be noted that the SIE data presented throughout this chapter indicate persons as covered by health insurance if they are covered either through their own employment (or individual policy) or if they are covered by a family member's policy. Thus, rates of insurance coverage by occupation do not strictly correspond to the availability of insurance to employees within that occupation. For example, a woman employed as a private household worker may not have coverage through her employment but will be shown as covered if she is insured through her husband's employment. Differences in marital status between groups may thus affect coverage rates.

<sup>26</sup> In 1976, 2.2 percent of employed white women were private household workers while 9.4 percent of employed minority women were similarly employed. U.S., Department of Labor, Bureau of Labor Statistics, *Handbook of Labor Statistics* (December 1980), bulletin 2070, table 20, p. 47.

<sup>25</sup> Dickerson, *Health Insurance*, pp. 551-54; Gregg and Lucas, *Handbook*, pp. 341-42 and 435-38.

<sup>26</sup> The insurance coverage rate for black male transport equipment operatives is not significantly lower than that for similarly employed majority males, at the 0.05 level of statistical confidence.

<sup>27</sup> In 1970 approximately 1.1 percent of employed whites were farm laborers; 3.5 percent of employed black men and 5.4 percent of employed men of Spanish heritage reported farm laborer or foreman as their occupation. U.S., Department of Commerce, Bureau of the Census, *General Social and Economic Characteristics*, 1970 Census of Population, no. PC(1)-C1, U.S. Summary, table 91, p. 1-392. Also see appendix tables B.1 and B.2 for the distribution by occupation and industry of each population group shown in tables 3.2 and 3.3. See also Vecchio and Cerda, "Discrimination Against Farmworkers," *Consultation*, vol. 1, p. 519.

<sup>28</sup> However, the insurance coverage rate for American Indian female operatives (excluding transport) and black female service

**TABLE 3.2****Percentage of Employed Persons 14 to 64 Years Old with Health Insurance Coverage, by Occupation, Race or Ethnicity, and Sex: 1976**

| Race or ethnicity and sex                      | Occupation*        |                                    |  |       |          |                    |                                      |                                      |                     |                                 |   |                  |
|--|--------------------|------------------------------------|--|-------|----------|--------------------|--------------------------------------|--------------------------------------|---------------------|---------------------------------|---|------------------|
|  | Total <sup>b</sup> | Profession-<br>al and<br>technical | Manag-<br>ers and<br>adminis-<br>trators | Sales | Clerical | Crafts-<br>workers | Operatives,<br>except trans-<br>port | Transport<br>equipment<br>operatives | Nonfarm<br>laborers | Private<br>household<br>workers | Service, ex-<br>cept private<br>household | Farm<br>laborers |
| <b>Majority</b>                                |                    |                                    |  |       |          |                    |                                      |                                      |                     |                                 |   |                  |
| Males  | 91.8               | 95.8                               | 94.3                                     | 93.1  | 93.8     | 91.8               | 94.0                                 | 87.4                                 | 84.0                | —                               | 90.1                                      | 78.6             |
| Females  | 92.0*              | 96.0*                              | 93.7*                                    | 91.5* | 94.1*    | 87.4*              | 93.0*                                | 90.1*                                | 83.6*               | 82.8                            | 86.1                                      | 82.6*            |
| <b>Black</b>                                   |                    |                                    |  |       |          |                    |                                      |                                      |                     |                                 |   |                  |
| Males  | 85.1               | 89.5                               | 84.6                                     | 83.8  | 90.6     | 87.9               | 90.8                                 | 85.1*                                | 78.3                | —                               | 84.4                                      | 44.4             |
| Females  | 88.1               | 95.1*                              | 92.0*                                    | 82.3  | 92.2*    | 90.5*              | 88.1                                 | —                                    | 87.0*               | 66.0                            | 87.8*                                     | —                |
| <b>Hispanic</b>                                |                    |                                    |  |       |          |                    |                                      |                                      |                     |                                 |   |                  |
| Males  | 77.9               | 91.2                               | 86.2                                     | 85.1  | 89.6     | 77.0               | 82.7                                 | 75.9                                 | 76.1                | —                               | 72.9                                      | 30.2             |
| Females  | 81.1               | 91.9                               | 87.9                                     | 84.6  | 89.1     | —                  | 81.1                                 | —                                    | —                   | 45.0                            | 75.9                                      | —                |
| <b>Asian &amp; Pacific<br/>Island American</b> |                    |                                    |  |       |          |                    |                                      |                                      |                     |                                 |   |                  |
| Males  | 84.4               | 93.9*                              | 83.9                                     | 78.4  | 93.1*    | 88.7*              | 77.9                                 | 80.4*                                | 90.6                | —                               | 64.9                                      | —                |
| Females  | 86.4               | 97.3*                              | 98.5*                                    | 81.2  | 92.5*    | —                  | 79.9                                 | —                                    | —                   | —                               | 74.3                                      | —                |
| <b>American Indian</b>                         |                    |                                    |  |       |          |                    |                                      |                                      |                     |                                 |   |                  |
| Males  | 74.4               | 81.9                               | 85.1                                     | —     | —        | 71.7               | 81.2                                 | —                                    | 62.3                | —                               | 66.1                                      | —                |
| Females  | 79.6               | —                                  | —  | —     | 82.4     | —                  | 93.7*                                | —                                    | —                   | —                               | 68.9                                      | —                |

\* There were too few cases to show data for the occupation of farmers and farm managers.

<sup>b</sup> Excludes persons covered by medicaid or medicare, receiving supplemental security income (SSI), public assistance or welfare payments. See appendix A.

\* The difference between this value and the corresponding value for majority males is not statistically significant at the 0.05 level of confidence. The values for private household workers, however, were compared with the corresponding value for majority females. See appendix A for data source and sampling information.

— A value is not available due to an insufficient sample size. Appendix A contains the sample size for all population groups shown in each table.

Source: Special tabulations from the Survey of Income and Education, 1976.

**TABLE 3.3****Percentage of Employed Persons 14 to 64 Years Old with Health Insurance, by Industry, Race or Ethnicity, and Sex: 1976**

| Race or ethnicity and sex       | Industry <sup>a</sup> |             |              |                              |                                 |   |                 |              |                                    |                              |                            |   |                       |                       |
|---------------------------------|-----------------------|-------------|--------------|------------------------------|---------------------------------|---|-----------------|--------------|------------------------------------|------------------------------|----------------------------|---|-----------------------|-----------------------|
|                                 | Total <sup>b</sup>    | Agriculture | Construction | Manufacturing, durable goods | Manufacturing, nondurable goods | Transportation, communication; and public utilities | Wholesale trade | Retail trade | Finance insurance, and real estate | Business and repair services | Private household services | Personal services, except private household | Professional services | Public administration |
| Majority                        |                       |             |              |                              |                                 |   |                 |              |                                    |                              |                            |   |                       |                       |
| Males                           | 91.8                  | 81.7        | 83.4         | 96.2                         | 94.5                            | 93.5  | 92.8            | 90.8         | 92.6                               | 89.9                         | 71.5                       | 81.4  | 94.3                  | 97.6                  |
| Females                         | 92.0*                 | 77.6*       | 92.1         | 96.5*                        | 93.5*                           | 96.1*   | 97.5            | 87.5         | 95.9                               | 91.4*                        | 83.0                       | 87.7  | 93.9*                 | 96.9*                 |
| Black                           |                       |             |              |                              |                                 |   |                 |              |                                    |                              |                            |   |                       |                       |
| Males                           | 85.1                  | 49.7        | 71.8         | 92.1                         | 92.7*                           | 88.2  | 86.8            | 77.7         | 89.3*                              | 69.9                         | —                          | 79.3*                                       | 88.8                  | 95.2                  |
| Females                         | 88.1                  | —           | —            | 92.7                         | 90.2                            | 94.0*   | —               | 83.7         | 95.9*                              | 81.7                         | 66.4                       | 78.4*                                       | 92.4                  | 92.7                  |
| Hispanic                        |                       |             |              |                              |                                 |   |                 |              |                                    |                              |                            |   |                       |                       |
| Males                           | 77.9                  | 41.4        | 69.7         | 89.3                         | 87.9                            | 88.6  | 88.0*           | 66.3         | 88.9*                              | 64.0                         | —                          | 77.8*                                       | 86.1                  | 94.0                  |
| Females                         | 81.1                  | 39.5        | —            | 87.6                         | 84.6                            | 93.9*   | —               | 80.1         | 95.0*                              | 68.3                         | 44.8                       | 77.6*                                       | 85.2                  | 87.4                  |
| Asian & Pacific Island American |                       |             |              |                              |                                 |   |                 |              |                                    |                              |                            |   |                       |                       |
| Males                           | 84.4                  | 89.5*       | 90.7         | 86.6                         | 83.6                            | 95.8*   | 85.5            | 74.9         | 97.2*                              | —                            | —                          | 78.6*                                       | 88.5                  | 96.4*                 |
| Females                         | 86.4                  | —           | —            | —                            | 82.9                            | —   | —               | 82.8         | 90.8*                              | —                            | —                          | 82.7*                                       | 90.9                  | 99.3*                 |
| American Indian                 |                       |             |              |                              |                                 |   |                 |              |                                    |                              |                            |   |                       |                       |
| Males                           | 74.4                  | 56.4        | 58.5         | 86.7                         | —                               | 84.0  | —               | 74.2         | —                                  | —                            | —                          | —   | 72.9                  | 81.2                  |
| Females                         | 79.6                  | —           | —            | —                            | —                               | —   | —               | 81.4         | —                                  | —                            | —                          | —   | 79.3                  | —                     |

<sup>a</sup> There were too few cases to show data for the mining and entertainment industries.

<sup>b</sup> Excludes persons covered by medicaid or medicare, receiving supplemental security income (SSI), public assistance or welfare payments. See appendix A.

\* The difference between this value and the corresponding value for majority males is not statistically significant at the 0.05 level of confidence. The values for private household service workers, however, were compared with the corresponding value for majority females. See appendix A for data source and sampling information.

— A value is not available due to an insufficient sample size. Appendix A contains the sample size for all population groups shown in each table.

Source: Special tabulations from the Survey of Income and Education, 1976.

agriculture, construction, retail trade, and business and repair services.<sup>31</sup> For example, within the retail trade industry, 91 percent of majority males, 78 percent of black men, about 74 percent of Asian and Pacific Island American and American Indian men, and 66 percent of Hispanic men have health insurance.

Women generally have lower health insurance rates than majority men in manufacturing, retail trade, and professional services.<sup>32</sup> Women in private household services, however, are among the least likely to have insurance.

The relatively low health insurance coverage rates among laborers (farm or nonfarm), private household workers, and employees in the agricultural, construction, retail trade, business repair, or household service industries is affected, in part, by the insurance industry's general reluctance to underwrite individuals or groups employed in seasonal, transitory, or part-time jobs.<sup>33</sup> There is some evidence that the majority of establishments (80 percent) that do not offer health insurance plans are in the construction, retail trade, and service industries.<sup>34</sup> These industries are characterized by intermittent or temporary employment and a relatively high proportion of part-time, low-wage, or self-employed workers, which means fewer resources to be used for health insurance.<sup>35</sup> A relative lack of union representation has also been suggested as a reason for the low levels of insurance coverage of workers in these industries.<sup>36</sup>

However, even within generally stable, high-paying, or heavily unionized occupations and industries

(where the majority of workers find employment), health insurance coverage rates for minority workers remain lower than those for majority employees. These disparities indicate a need for the insurance industry to direct its attention toward the potential market that these minority groups represent as better risks.

### Class of Worker

Even though employed, people who do not have access to employment-related group insurance or who work less than a full workweek experience a considerable disadvantage in obtaining health insurance. Self-employed persons, who are usually precluded from obtaining group coverage through the workplace, are the least likely of all employed persons to have health insurance.<sup>37</sup> (See appendix table B.3.) Self-employed majority men, however, are more likely to have insurance coverage than self-employed black, Hispanic, or American Indian men. While four out of every five self-employed majority men have some form of health insurance coverage, approximately three in every five self-employed black and Hispanic men and approximately two in five American Indian men are covered.

Part-time employees are considerably less likely than full-time employees to be covered by one or more health insurance plans.<sup>38</sup> (See appendix table B.4.) The relative lack of insurance protection offered to part-time workers has a disproportionate effect on employed women because they are the majority of the part-time work force.<sup>39</sup> In addition, minority part-time workers of both sexes are consid-

<sup>31</sup> Asian and Pacific Island American men employed in the agriculture and construction industries, however, do not have significantly lower health insurance rates than similarly employed majority men, at the 0.05 level of statistical confidence.

<sup>32</sup> However, majority women employed in manufacturing do not have significantly lower health insurance rates than majority men employed in the same industry.

<sup>33</sup> Dickerson, *Health Insurance*, pp. 551-54 and Gregg and Lucas, *Handbook*, pp. 341-42, 435-38; John K. Booth, vice president and chief actuary, American Council of Life Insurance, and Thomas J. Gillooly, associate general counsel, Health Insurance Association of America, letter to Rep. James Scheuer, Dec. 12, 1980. Intermittently or temporarily employed persons are viewed with caution because it can be difficult to determine whether they are employed at the time some covered expense is incurred. Daniel F. Case, actuary, American Council of Life Insurance, letter to John Hope III, Acting Staff Director, U.S. Commission on Civil Rights, Dec. 23, 1981. Coverage for part-time workers is also partially a result of the employer's or union's agreement to cover these employees. James L. Moorefield, president, Health Insurance Association of America, letter to John Hope III, Acting Staff Director, U.S. Commission on Civil Rights, Dec. 23, 1981.

<sup>34</sup> Suresh Malhotra, Battelle Human Affairs Research Centers, *Employment Related Health Benefits in Private Nonfarm Business Establishments in the United States* (Springfield, Va.: National Technical Information Service, June 1980), vol. 1, no. PB81-174310, p. 6 (hereafter cited as *Employment Related Health Benefits*).

<sup>35</sup> *Haves and Have-Nots*, p. 20.

<sup>36</sup> U.S., Department of Health, Education, and Welfare, National Center for Health Statistics, *Health Care Coverage: United States, 1976*, Advance Data, no. 44 (Sept. 20, 1979), p. 7, (hereafter cited as *Health Care Coverage*).

<sup>37</sup> However, the insurance coverage rate for self-employed black women is not significantly lower than that for black women employed in private industry, at the 0.05 level of statistical confidence.

<sup>38</sup> The insurance coverage rate for American Indian women employed part time is not significantly lower than that for full-time workers, at the 0.05 level of statistical confidence.

<sup>39</sup> In 1976 approximately 74 percent of all part-time employees 20 years and over were female. *Handbook of Labor Statistics*, table 6, p. 19.

erably less likely to be insured than their majority counterparts. Except for female American Indian employees, working part time reduces insurance coverage for minorities more than it does for the majority population. For example, approximately 5 percent fewer majority female part-time workers have health insurance than do such women in full-time positions. In contrast, part-time work reduces health insurance coverage by 12 percent for black women.<sup>40</sup>

### Income

Total family income, like employment status, is an important factor associated with health insurance coverage rates. It not only reflects a person's (or family's) position and relative remuneration within the labor force, it also indicates the ability to purchase individual health insurance if group coverage is unavailable. As shown in table 3.4, regardless of race, ethnic background, or sex, the higher the annual income, the greater the probability of having insurance coverage. Even at the highest income levels, however, blacks, Hispanics, and American Indians are less likely to have insurance than the majority population. Only Asian and Pacific Island American women with annual family incomes of \$15,000 and over achieve statistical parity with the majority population in health insurance coverage.

Middle- to low-income minorities are also consistently less likely to have health insurance coverage than majority persons of the same sex and income level.<sup>41</sup> Of all income groups, the greatest differential between majority and minority insurance coverage rates exists for persons with a family income of less than \$5,000 per year. Over three-fifths of majority persons at this income level have health insurance. The insurance coverage rate for minori-

ties is much lower; about half of all blacks and two-fifths of all Hispanics, Asian and Pacific Island Americans, and American Indians with annual incomes of less than \$5,000 are covered by health insurance.

The fact that high-income persons are more likely to have health insurance coverage reflects, to some degree, the widespread access to work-related health benefits that generally characterizes moderate- to high-salaried positions (\$10,000 or more per year).<sup>42</sup> In addition, persons with medium to high incomes can more easily afford individual insurance coverage if health benefits are not otherwise available. However, even though most minorities have family incomes of over \$10,000 per year,<sup>43</sup> they are generally less likely to have health insurance than their majority counterparts at this income level. This is a group of minorities that has the economic means to purchase insurance but is not being reached by the insurance industry.

Persons with low incomes may find health insurance coverage particularly difficult to acquire because of part-time, seasonal, or temporary employment.<sup>44</sup> Unemployment may also reduce family income and eliminate health insurance benefits. In addition, many low-income persons or families may find individual insurance to be prohibitively expensive.<sup>45</sup> The insurance industry, in turn, uses marketing and underwriting practices that may make it more difficult for low-income persons to obtain insurance.<sup>46</sup> For example, as part of group and individual insurance underwriting, income is sometimes used as an indicator of living standards and predictor of poor health.<sup>47</sup> Such practices have particular relevance for female heads of families and minorities because they are disproportionately represented among low-income families.<sup>48</sup>

<sup>40</sup> Women who are employed part time may be covered through their husband's health insurance. A lower percentage of black than majority women may have access to coverage by this means. See figures 3.1 and 3.2 and table 3.6.

<sup>41</sup> Asian women with a family income of \$5,000 to \$9,999, however, do not have significantly lower insurance coverage rates than majority women with a similar family income, at the 0.05 level of statistical confidence.

<sup>42</sup> For example, among professionals approximately 5 percent were uninsured in 1976, while among farm laborers and farm foremen, approximately 41 percent were uninsured. *Health Care Coverage*, p. 5. Other research has shown that nearly 80 percent of employees in establishments without health insurance plans were low-wage workers, making \$10,000 or less per year in 1977-78. Nearly half of these workers made less than \$6,000 per year. Malhotra, *Employment Related Health Benefits*, p. 12.

<sup>43</sup> See appendix table B.5.

<sup>44</sup> Among all racial and ethnic groups, the number of earners working full time, full year declines as family income falls. In families with an income of less than \$4,000 per year, there are fewer full-time, full-year earners among blacks and Hispanics than among whites. However, in families with an income of \$4,000 or greater, this is reversed. U.S., Department of Commerce, Bureau of the Census, *Money Income in 1975 of Families and Persons in the United States*, series P-60, no. 105, table 26, pp. 112-13 (hereafter cited as *Money Income*).

<sup>45</sup> *Haves and Have-Nots*, p. 40.

<sup>46</sup> Denenberg, "Overview Report," *Consultation*, vol. 1, pp. 268, 276-78. Dickerson, *Health Insurance*, pp. 551-53. Gregg and Lucas, *Handbook*, pp. 341-42, 435-36.

<sup>47</sup> *Ibid.*

<sup>48</sup> For example, while 5.5 percent of all majority men are members of families with incomes under \$5,000 per year, 14

## Age, Marital Status, and Family Characteristics

Individual and family characteristics such as age, marital status, and family head status are also important determinants of health insurance coverage. Because of the predominance of group health insurance, many people, particularly homemakers, children, and young adults, do not have coverage in their own name but through another family member who stands as the primary insured. For these individuals, the relationship to the primary insured becomes the means through which health insurance is acquired or lost. As a result, the death of or divorce from the primary insured leaves them particularly vulnerable to loss of health insurance coverage.

### Age

Although some disparity between majority and minority health insurance coverage rates is evident for all age groups, the biggest difference exists among youths 14 to 18. (See table 3.5.) Approximately 9 out of 10 majority youths of this age have health insurance. In contrast, less than three-fifths of American Indians, approximately two-thirds of Hispanic and Asian and Pacific Island Americans, and three-quarters of all blacks aged 14 to 18 are insured. Minorities aged 19 to 24 are also less likely to have health insurance coverage than their majority counterparts at an age when coverage rates generally dip regardless of race, sex, or ethnicity.

Majority and minority youths aged 14 to 24 may be covered by a family member's policy while in school or may have acquired their own insurance through employment. However, many insurance policies do not cover family members over 18 unless

percent of blacks, 13 percent of Hispanics, 12 percent of Asian and Pacific Islanders and 17 percent of American Indians have comparable family incomes. Minorities are also more likely than majority men to have family incomes of \$5,000 to \$10,000 per year. In addition, in 1975, 55.4 percent of all female family heads were in families with an income of under \$10,000 per year. In contrast, 16.1 percent of majority male family heads were members of such families. See special tabulations of the 1976 Survey of Income and Education, appendix table B.5.

<sup>49</sup> *Have and Have-Nots*, pp. 18-19.

<sup>50</sup> *Ibid.*

<sup>51</sup> For instance, in 1976, 47.8 percent of black males aged 16-19 were unemployed as compared with a 15.0 percent unemployment rate among majority males of the same age. *Social Indicators*, pp. 32-34.

<sup>52</sup> In 1976, 20.7 percent of black and other racial minority men aged 20-24 were unemployed as compared with 10.9 percent of white males of this age. *Handbook of Labor Statistics*, table 32, pp. 69-70.

they are in school.<sup>49</sup> Further, those who are not in school are more likely to lack coverage if they are unemployed, are in jobs that do not provide insurance, or are laid off from jobs that do not provide insurance as part of layoff protection.<sup>50</sup>

In part, minority youths aged 14 to 18 have lower insurance coverage rates because their parents do not have family insurance coverage. As shown in appendix table B.6, at younger ages, minority children are less likely to be covered by a family policy. In addition, the relatively high unemployment rates for minority youths of this age make it more difficult for them to acquire their own health insurance.<sup>51</sup> Older minority youths—those aged 20 to 24—also experience relatively high unemployment.<sup>52</sup> In addition, given lower college enrollment rates than for majority youths in this age group and the restrictions on continuing insurance for nonstudents past age 18, they are less likely to be insured under a family policy.<sup>53</sup> Although the majority of all black, Hispanic, Asian and Pacific Island American, and American Indian youths have health insurance, they are more likely than majority youths to have the usual avenues of acquiring health insurance (family or employment) closed to them.

### Marital Status

Marital status, particularly for women, also serves as an important determinant of health insurance coverage. Married women, regardless of race or national origin, are more likely to have health insurance than widowed, divorced, separated, or never-married women.<sup>54</sup> These data are shown in table 3.6.

There are a number of reasons for these differences in coverage. Being married offers the possibili-

<sup>53</sup> In 1976, 27.1 percent of white youths aged 18-24 were enrolled in college. In contrast 22.6 percent of black youths and 19.9 percent of Spanish-origin youths of this age were enrolled. U.S., Department of Commerce, Bureau of the Census, *School Enrollment—Social and Economic Characteristics of Students: October 1976*, Current Population Reports, series P-20, no. 319 (February 1978), table 1, pp. 11-12.

<sup>54</sup> The National Association of Insurance Commissioners (NAIC) Model Regulation to Eliminate Unfair Sex Discrimination, in part, prohibits denial of insurance coverage on the basis of marital status. As of April 1981, 11 States (Arizona, Arkansas, Florida, Iowa, Nebraska, Nevada, Pennsylvania, Tennessee, Texas, Utah, and Wisconsin) had adopted regulations closely patterned after the NAIC model regulation. Ten other States (California, Illinois, Kansas, Massachusetts, Michigan, Montana, New York, North Carolina, Oregon, and Washington) had adopted modified versions. *Official NAIC Model Laws, Regulations and Guidelines* (Minneapolis, Minn.: NIARS Corp., 1977),



ty of acquiring coverage through the husband's policy if the woman herself is not employed or does not otherwise have access to group insurance. In addition, regardless of whether she works outside the home, women in husband-wife families have much higher family incomes than women who head families by themselves or women who do not live with other family members.<sup>55</sup> As discussed earlier, a high family income is associated with a high level of insurance coverage.

Some of the differences in insurance coverage that exist between women of different racial or ethnic backgrounds disappear when comparisons are made among divorced or separated women. There is little difference in coverage rates among divorced majority and black women; approximately 17 percent are without health insurance. Divorced Hispanic, Asian and Pacific Island American, and American Indian women, however, are less likely to have coverage than divorced majority women. Regardless of race or ethnicity, separated women also experience similar rates of insurance coverage. Approximately 75 percent of all separated majority, black, and Hispanic women have insurance coverage.<sup>56</sup>

Divorced women have low rates of insurance coverage despite the conversion rights available through their ex-husbands' group health insurance policy (assuming such a policy). Conversion rights permit people to switch from a group to an individual policy without giving evidence of insurability (e.g., good health).<sup>57</sup> The cost of conversion policies may make it difficult for divorced women to acquire them. Given the lower incomes of female-headed families, the premiums for conversion policies with the same coverage as a prior group policy may be

vol. 1, pp. 160-4 and 5. Enforcement of these rules may be inhibited, however, by shortcomings in State insurance department complaint handling, market conduct examinations, and monitoring of underwriting practices. Improved use of these enforcement mechanisms would better assure compliance with the law. U.S., General Accounting Office, *Issues and Needed Improvements in State Regulation of the Insurance Business* (October 1979), pp. 41-57, 149-50, and 159-64.

<sup>55</sup> The median income for husband-wife families in 1975 was \$15,302 per year. For such families in which the wife worked the median income was \$17,581; when the wife was not in the paid labor force, the median income for husband-wife families was \$13,274. In families where the woman was the head of the family (no husband present), the median income was \$6,983 per year. Women living without any family members had a median income of \$4,239. *Money Income*, table 1A, pp. 7-8.

<sup>56</sup> Data are unavailable for separated Asian and Pacific Island American and American Indian women. See table 3.6.

<sup>57</sup> The NAIC has developed a Group Health Insurance Mandatory Conversion Privilege Model Act that provides conversion

prohibitive, since premium costs are no longer shared by the employer.

In addition, some insurers offer little incentive to agents to sell conversion policies by paying no commission or an unusually low commission.<sup>58</sup> This is done to offset the adverse selection thought to be involved in conversions.<sup>59</sup> Adverse selection here refers to a situation in which people who are most likely to need health insurance for medical reasons are those most likely to avail themselves of the conversion privilege.<sup>60</sup> State group conversion laws specify benefits to be contained in policies once sold, but are silent on possible disincentives to agents selling conversion policies.<sup>61</sup>

### Family Characteristics

Persons who head families, in addition to providing insurance for themselves, must often be responsible for insuring dependents. While 93.5 percent of majority male family heads (and presumably their dependents) have insurance coverage, black and Asian and Pacific Island American male family heads have health insurance coverage rates of between 88 and 89 percent. Male Hispanic and American Indian family heads are even less likely to have insurance, with coverage rates of 79.5 and 76.2 percent, respectively. These data are shown in figure 3.2.

Irrespective of race or ethnicity, health insurance is less prevalent among female than male heads of families. Fifteen percent of majority female family heads, approximately 22 percent of black female family heads, and over 33 percent of all families headed by Hispanic, Asian and Pacific Island Ameri-

rights to employees or members whose insurance under a group policy is terminated for reasons other than nonpayment of premiums. "Group Health Insurance Mandatory Conversion Privilege Model Act," *NAIC Model Laws*, vol. 1, pp. 410-1 to 410-8 (hereafter cited as "Conversion Privilege Model Act"). It also provides conversion privileges to the surviving spouse, if any, at the death of an employee and to spouses of covered employees when they no longer are qualified family members (e.g., divorced). Notification of the conversion privilege is required to be included in the certificate of coverage. As of January 1979, 12 States had adopted this regulation, some with modifications that more explicitly extend conversion rights upon divorce and annulment and some that provide for more stringent notification of conversion rights to assure a person's knowledge of his or her eligibility. *Ibid.*, pp. 410-7 and 8.

<sup>58</sup> Dickerson, *Health Insurance*, p. 541.

<sup>59</sup> *Ibid.*, pp. 641-42.

<sup>60</sup> *Ibid.*, p. 642.

<sup>61</sup> "Conversion Privilege Model Act," *NAIC Model Laws*, pp. 410-1 to 410-8.

**TABLE 3.4****Percentage of Persons 14 to 64 Years Old with Health Insurance, by Total Family Income in 1975, Race or Ethnicity, and Sex: 1976**

| Race or ethnicity and sex       | Total Family Income |                            |                    |                      |                   |
|---------------------------------|---------------------|----------------------------|--------------------|----------------------|-------------------|
|                                 | Total <sup>a</sup>  | Under \$5,000 <sup>b</sup> | \$5,000 to \$9,999 | \$10,000 to \$14,999 | \$15,000 and over |
| Majority                        |                     |                            |                    |                      |                   |
| Males                           | 90.1                | 63.3                       | 78.0               | 90.4                 | 95.3              |
| Females                         | 90.3*               | 67.8                       | 82.0               | 92.0                 | 95.4*             |
| Black                           |                     |                            |                    |                      |                   |
| Males                           | 79.1                | 50.8                       | 71.8               | 84.5                 | 89.8              |
| Females                         | 81.1                | 54.2                       | 75.8               | 88.3                 | 93.1              |
| Hispanic                        |                     |                            |                    |                      |                   |
| Males                           | 73.1                | 40.0                       | 63.5               | 80.7                 | 86.7              |
| Females                         | 74.6                | 40.2                       | 63.9               | 83.3                 | 90.2              |
| Asian & Pacific Island American |                     |                            |                    |                      |                   |
| Males                           | 78.6                | 41.8                       | 66.4               | 73.3                 | 92.8              |
| Females                         | 83.2                | 37.6                       | 75.1*              | 84.4                 | 95.5*             |
| American Indian                 |                     |                            |                    |                      |                   |
| Males                           | 67.5                | 34.2                       | 55.0               | 74.7                 | 86.9              |
| Females                         | 71.4                | 36.6                       | 66.2               | 81.4                 | 90.5              |

<sup>a</sup> Excludes persons covered by medicaid or medicare, receiving supplemental security income (SSI), public assistance, or welfare payments. See appendix A.

<sup>b</sup> Includes a small number of persons with a negative family income.

\* The difference between this value and the corresponding value for majority males is not statistically significant at the 0.05 level of confidence. See appendix A for data source and sampling information.

Source: Special tabulations from the Survey of Income and Education, 1976.

**TABLE 3.5****Percentage of Persons 14 to 64 Years Old with Health Insurance Coverage, by Age, Race or Ethnicity, and Sex: 1976**

| Race or ethnicity and sex       | Total <sup>a</sup> | Age   |       |       |       |       |       |
|---------------------------------|--------------------|-------|-------|-------|-------|-------|-------|
|                                 |                    | 14-18 | 19-24 | 25-34 | 35-44 | 45-54 | 55-64 |
| Majority                        |                    |       |       |       |       |       |       |
| Males                           | 90.1               | 92.2  | 81.7  | 89.2  | 91.8  | 93.3  | 93.1  |
| Females                         | 90.3*              | 89.1  | 82.6* | 92.0  | 92.8* | 92.4* | 91.5  |
| Black                           |                    |       |       |       |       |       |       |
| Males                           | 79.1               | 74.9  | 69.9  | 81.3  | 82.2  | 84.3  | 83.8  |
| Females                         | 81.1               | 75.4  | 77.6  | 85.9  | 83.7  | 83.1  | 77.6  |
| Hispanic                        |                    |       |       |       |       |       |       |
| Males                           | 73.1               | 66.2  | 61.3  | 75.9  | 78.8  | 80.8  | 76.2  |
| Females                         | 74.6               | 68.9  | 68.9  | 76.6  | 80.3  | 78.4  | 74.3  |
| Asian & Pacific Island American |                    |       |       |       |       |       |       |
| Males                           | 78.6               | 66.5  | 58.0  | 83.8  | 94.1* | 80.9  | 77.9  |
| Females                         | 83.2               | 68.8  | 69.0  | 91.3* | 89.7* | 80.0  | 84.1  |
| American Indian                 |                    |       |       |       |       |       |       |
| Males                           | 67.5               | 57.5  | 57.4  | 72.1  | 75.3  | 68.2  | 72.2  |
| Females                         | 71.4               | 59.2  | 60.0  | 81.9  | 75.1  | 75.7  | 76.5  |

<sup>a</sup> Excludes persons covered by medicaid or medicare, receiving supplemental security income (SSI), public assistance, or welfare payments. See appendix A.

\* The difference between this value and the corresponding value for majority males is not statistically significant at the 0.05 level of confidence. See appendix A for data source and sampling information.

Source: Special tabulations from the Survey of Income and Education, 1976.

**TABLE 3.6****Percentage of Women 14 to 64 Years Old with Health Insurance Coverage, by Marital Status and Race or Ethnicity: 1976**

| Race or ethnicity               | Marital status |         |         |          |           |               |
|---------------------------------|----------------|---------|---------|----------|-----------|---------------|
|                                 | Total*         | Married | Widowed | Divorced | Separated | Never married |
| Majority                        | 90.3           | 92.0    | 89.0    | 85.1     | 78.4      | 87.6          |
| Black                           | 81.1           | 87.6    | 66.0    | 81.5*    | 73.3*     | 75.4          |
| Hispanic                        | 74.6           | 79.0    | 52.1    | 72.4     | 73.4*     | 67.2          |
| Asian & Pacific Island American | 83.2           | 88.5    | 64.0    | 71.4     | —         | 72.8          |
| American Indian                 | 71.4           | 76.9    | —       | 66.9     | —         | 65.0          |

\* Excludes persons covered by medicaid or medicare, receiving supplemental security income (SSI), public assistance, or welfare payments. See appendix A.

\* The difference between this value and the corresponding value for majority females is not statistically significant at the 0.05 level of confidence. See appendix A for data source and sampling information.

— A value is not available due to an insufficient sample size. Appendix A contains the sample size for all population groups shown in each table.

Source: Special tabulations from the Survey of Income and Education, 1976.

can, and American Indian women are without insurance.

Even women who are employed do not attain parity in insurance coverage with employed male family heads, as shown in table 3.7. Ten percent of majority female family heads who are employed, 15 percent of employed black female heads, and 25 percent of employed Hispanic women who head families are without insurance coverage. As the Congressional Budget Office study *Profile of Health Care Coverage: The Haves and Have-Nots* notes: "In four out of five cases when an employed family head lacks coverage, his [or her] family is without coverage as well. Therefore, lack of insurance coverage among this group has ramifications for a much larger group of people."<sup>62</sup>

The relative absence of health insurance among minority family heads is, in fact, closely tied to differences in coverage between majority and minority children. As shown in table 3.8, only 8 percent of majority children aged 0 to 13 years old are not covered by some form of health insurance. In contrast, 17 percent of Asian and Pacific Island American children, 23 percent of black children, and 27 percent of Hispanic children are uninsured. Approximately 40 percent of American Indian chil-

dren lack health insurance coverage. Even at medium to high family income levels, which encompass the majority of black, Hispanic, and Asian and Pacific Island American children, minority children, like minority adults, have lower rates of insurance coverage than their majority counterparts.<sup>63</sup> This is another instance in which the insurance industry is not fully extending its marketing effort to minorities who could meet the premium cost of insurance.

The lower the family income the less chance a child has of being covered by health insurance. There is, however, a significant difference in coverage rates between minority and majority children especially at the lowest income levels. Over two-thirds of majority children but less than half of all minority children in families with an annual income of less than \$5,000 per year are covered by insurance. Not only are minority children in low-income families less likely to have health insurance coverage than similarly situated majority children, but a greater proportion of minority children are members of low-income families. (See table 3.8.)

Minority infants also have particularly low rates of insurance coverage, despite the fact that most

likely to have health insurance than similarly situated majority children, at the 0.05 level of confidence.

<sup>62</sup> *Haves and Have-Nots*, p. 26.

<sup>63</sup> Asian and Pacific Island American children in families with incomes over \$15,000 per year, however, are not significantly less

**FIGURE 3.2**

**Percentage of Family Heads 14 to 64 Years Old with Health Insurance Coverage, by Race or Ethnicity, and Sex: 1976**

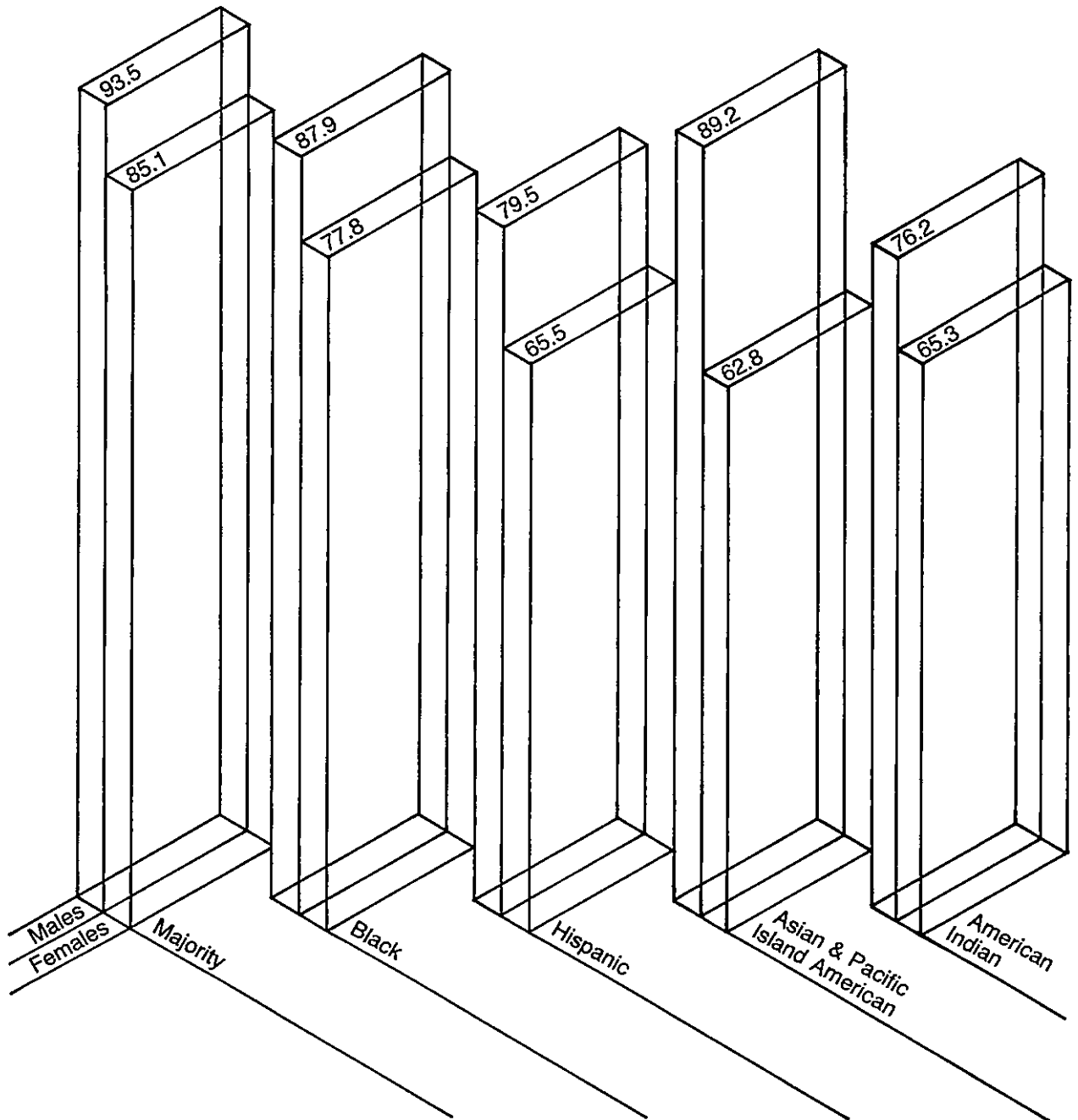

Note: Excludes persons covered by medicaid or medicare, receiving supplemental security income (SSI), public assistance, or welfare payments. See appendix A for data source and sampling information.  
Source: Special tabulations from the Survey of Income and Education, 1976.

**TABLE 3.7****Percentage of Family Heads 14 to 64 Years Old with Health Insurance Coverage, by Employment Status, Race or Ethnicity, and Sex: 1976**

| Race or ethnicity <sup>a</sup> and sex | Total <sup>b</sup> | Employment status |            |                    |
|--|--------------------|-------------------|------------|--------------------|
|  |                    | Employed          | Unemployed | Not in labor force |
| Majority                               |                    |                   |            |                    |
| Males                                  | 93.5               | 94.5              | 69.7       | 86.2               |
| Females                                | 85.1               | 90.3              | —          | 75.7               |
| Black                                  |                    |                   |            |                    |
| Males                                  | 87.9               | 90.2              | 55.6       | 71.3               |
| Females                                | 77.8               | 84.6              | 53.0       | 47.2               |
| Hispanic                               |                    |                   |            |                    |
| Males                                  | 79.5               | 82.4              | 43.1       | 53.8               |
| Females                                | 65.5               | 74.1              | —          | 39.4               |

<sup>a</sup> There were too few cases to show data for Asian and Pacific Island Americans and American Indians.

<sup>b</sup> Excludes persons covered by medicaid or medicare, receiving supplemental security income (SSI), public assistance, or welfare payments. See appendix A for data source and sampling information.

— A value is not available due to an insufficient sample size. Appendix A contains the sample size for all populations groups shown in each table.

Source: Special tabulations from the Survey of Income and Education, 1976.

States require insurance coverage of newborn infants if the parents are insured.<sup>64</sup> However, these laws clearly have no effect on infants whose parents are uninsured.<sup>65</sup> Black and Hispanic children under 1 year of age are less likely to be covered by health insurance than majority children or children of older ages. One out of 10 majority children under 1 year of age is uninsured; 3 in 10 black infants and slightly less than one-third of Hispanic children under 1 year are without some form of insurance coverage. (See appendix table B.6.)

In addition, data from the 1972 National Natality Survey show that the mothers of black infants are also less likely than mothers of white infants to have insurance coverage for prenatal care or hospital and physician expenses at the time of delivery. In 1972, 53.2 percent of mothers who gave birth to white infants had insurance for prenatal care, compared with 43.5 percent of mothers of black infants.

<sup>64</sup> "Model Newborn Children Bill," *NAIC Model Laws*, vol. 1, pp. 130-2 to 130-4.

<sup>65</sup> *Ibid.*

<sup>66</sup> The 1972 National Natality Survey (NNS) is a nationally representative survey of infant birth registrations. Because of a lack of current comprehensive data on maternity coverage, either through sample surveys or from the insurance industry, 1972 NNS data are presented here. One drawback of this survey is that

Approximately two-thirds of the mothers of white infants were covered by hospital insurance and 60 percent had physician expense coverage during delivery. In contrast, slightly more than half (51.8 percent) of the mothers of black infants had hospital coverage at the time of delivery, and less than half (47.2 percent) had physician care coverage.<sup>66</sup>

Since the 1972 survey, Congress passed the Pregnancy Discrimination Act of 1978,<sup>67</sup> which requires that employers who have 15 or more employees and who provide insurance must cover the costs of pregnancy the same as any other illness in their group insurance benefit plans. However, since this law applies to health insurance obtained through employment, racial disparities may still persist in access to pregnancy coverage because of racial differences in employment status and social and economic characteristics that are associated with access to health insurance.

births reported or inferred as out of wedlock were eliminated from the sample. Marcie L. Cynamon and Paul J. Placek, National Center for Health Statistics, "Insurance Coverage for Prenatal Care, Hospital Stay, and Physician Care: United States, 1964-66 and 1972 National Natality Surveys" (paper delivered at the American Public Health Association Poster Session, New York, N.Y., Nov. 4-8, 1979), table 1.

<sup>67</sup> U.S.C. §2000e(k) (Supp. III 1979).

**TABLE 3.8****Percentage of Children 0 to 13 Years Old with Health Insurance Coverage and of All Children by Family Income and Race or Ethnicity: 1976**

| Race or ethnicity                | Total family income in 1975 |                            |                    |                      |                   |
|----------------------------------|-----------------------------|----------------------------|--------------------|----------------------|-------------------|
|                                  | Total <sup>a</sup>          | Under \$5,000 <sup>b</sup> | \$5,000 to \$9,999 | \$10,000 to \$14,999 | \$15,000 and over |
| Majority                         |                             |                            |                    |                      |                   |
| With insurance                   | 91.7                        | 68.7 <sup>c</sup>          | 79.3               | 92.6                 | 96.7              |
| Of children in each income group | 100.0                       | 5.1 <sup>d</sup>           | 14.7               | 25.7                 | 54.5              |
| Black                            |                             |                            |                    |                      |                   |
| With insurance                   | 77.4                        | 43.9                       | 70.9               | 86.7                 | 92.6              |
| Of children in each income group | 100.0                       | 14.8                       | 30.4               | 24.9                 | 29.9              |
| Hispanic                         |                             |                            |                    |                      |                   |
| With insurance                   | 73.2                        | 30.5                       | 62.0               | 80.0                 | 91.2              |
| Of children in each income group | 100.0                       | 9.8                        | 29.4               | 30.9                 | 29.9              |
| Asian & Pacific Island American  |                             |                            |                    |                      |                   |
| With insurance                   | 82.9                        | 49.5                       | 57.7               | 82.8                 | 96.9*             |
| Of children in each income group | 100.0                       | 11.4                       | 16.0               | 16.5                 | 56.1              |
| American Indian                  |                             |                            |                    |                      |                   |
| With insurance                   | 59.7                        | 18.2                       | 59.0               | 75.8                 | 82.0              |
| Of children in each income group | 100.0                       | 19.5                       | 36.2               | 24.6                 | 19.7              |

<sup>a</sup> Excludes persons covered by medicaid or medicare, receiving supplemental security income (SSI), public assistance, or welfare payments. See appendix A.

<sup>b</sup> Includes a small number of children in families with a negative income.

<sup>c</sup> This can be interpreted as follows: "In 1976, 68.7 percent of majority children aged 0 to 13 in families with an income in 1975 of under \$5,000 had health insurance coverage."

<sup>d</sup> This can be interpreted as follows: "In 1976, 5.1 percent of majority children aged 0 to 13 were in families with an income in 1975 of under \$5,000."

\* The difference between this value and the corresponding value for majority children is not statistically significant at the 0.05 level of confidence. See appendix A for data source and sampling information.

Source: Special tabulations from the Survey of Income and Education, 1976.

## Health Limitation

Persons with health limitations or disabilities, while often most in need of health insurance coverage, are also less likely to have such coverage.<sup>68</sup> Health-limited<sup>69</sup> individuals are more likely to lack insurance, in part, because some are unable to work while others find it difficult to locate or continue on a job.<sup>70</sup> This greatly limits their ability to obtain group insurance through an employer. In addition, because of exclusions, restrictions, or high cost, people with a health limitation may be unable to purchase an individually written health insurance policy.

As shown in table 3.9, both majority and minority individuals with some degree of health limitation are comparatively less likely to have health insurance. Blacks and Hispanics with health limitations, however, are much more likely to be without health insurance than similarly situated members of the majority. Approximately one in three Hispanic and black health-restricted individuals are without insurance coverage compared with about one in six majority persons.

The presence of a health-limiting condition does not, however, reveal anything about the cause of the condition or its severity. The SIE data are not detailed enough to allow a comparison of health insurance coverage rates of similarly limited minorities and members of the majority taking into account the specific illness and the degree of its disabling effect.<sup>71</sup>

## State and National Health Insurance as Remedies

As the analysis of health insurance coverage rates demonstrates, many people do not have private

health insurance, because they possess health or other characteristics that make them poor risks and, in addition, do not meet the eligibility requirements for medicaid or medicare. These people, a disproportionate number of whom are minorities or unmarried or separated women, lack any form of coverage whatsoever against the substantial costs of health care. National health insurance or widespread adoption of State-mandated plans would provide a source of coverage for these groups.

The National Association of Insurance Commissioners (NAIC), a representative organization of State insurance commissioners, has adopted model comprehensive health care and catastrophic health insurance acts.<sup>72</sup> Respectively, these bills require health insurance carriers doing business in each State to provide comprehensive health insurance coverage or to provide coverage for health care expenses exceeding some catastrophic threshold.<sup>73</sup> In addition, in both cases specific benefits must be offered, rates and policy forms must be approved by the State insurance commissioner, and some form of reinsurance mechanism is required in order to spread the risk of providing insurance.<sup>74</sup> In both instances, the insurance industry provides health insurance, and the system is supported by premiums paid by insureds. The State plays an oversight role to assure compliance with the law and the financial soundness of the system. The State is neither the insurer nor the medical care provider; further, no State subsidies are provided.

In actuality, only three States (Minnesota, Rhode Island, and Maine) have mandated catastrophic health insurance and only four States (Minnesota, Hawaii, Connecticut, and Wisconsin) have enacted a comprehensive health insurance plan.<sup>75</sup> In every

<sup>68</sup> U.S., Department of Health, Education, and Welfare, National Center for Health Statistics, *Hospital and Surgical Insurance Coverage, United States—1974*, series 10, no. 117 (August 1977), p. 7. The National Association of Insurance Commissioners has developed a Model Regulation on Unfair Discrimination in Life and Health Insurance on the Basis of Physical or Mental Impairment and a Model Regulation on Unfair Discrimination on the Basis of Blindness or Partial Blindness. Their main purpose is to avoid arbitrary classification of the physically impaired that cannot be actuarially supported. The first rule has not been adopted by any State. The second has been adopted by 15 States, some with modifications. *NAIC Model Laws*, vol. 2, pp. 905-2 and 3.

<sup>69</sup> For the purpose of this analysis, health-limited individuals are those persons with a physical, mental, or emotional condition that interferes with or restricts their ability to do regular schoolwork (persons 14-25 only), take part in sports (persons 14-17 only),

work around the house, or which prevents or limits working at a job.

<sup>70</sup> Edward V. Roberts, "Into the Mainstream—The Civil Rights of People with Disabilities," *Civil Rights Digest*, Winter 1979, p. 24.

<sup>71</sup> Thus, the rates shown in table 3.9 reflect the age-specific incidence of disabling conditions within each population group, the age distribution of each group, and the severity of the health limitation as perceived by the individual.

<sup>72</sup> "Comprehensive Health Care and Cost Containment Model Act," *NAIC Model Laws*, vol. 1, pp. 80-1 to 80-31; "Catastrophic Health Insurance Model Act," *Ibid.*, pp. 70-1 to 70-10.

<sup>73</sup> *Ibid.*, p. 70-2. The comprehensive health insurance model also reaches self-insured employee health benefit plans, with certain exceptions. *Ibid.*, pp. 80-5 to 80-6.

<sup>74</sup> *Ibid.*, pp. 70-2 to 70-6 and 80-7 to 80-20.

<sup>75</sup> The catastrophic health insurance laws appear at Me. Rev.



instance, these State plans differ from the NAIC model laws in significant ways.

Of the three States with a catastrophic plan, all provide for direct reimbursement by the State of specified health care costs above certain monetary thresholds.<sup>76</sup> Thus, the programs are not self-amortizing but supported by the State. Insurance companies have no role except where the States may contract for insurers' services in meeting the States' responsibilities. The catastrophic limits that trigger State reimbursement, however, are rather high, and, even with the assistance received under these programs, some people can conceivably still have considerable out-of-pocket expenses.<sup>77</sup> In Rhode Island, the catastrophic thresholds are lower for people enrolled in "qualified" basic health insurance or major medical policies than for those who are not. "Qualified" plans are those that provide benefits enumerated in the law; insurers are required to submit policies for certification as "qualified" but are not required to offer "qualified" plans.<sup>78</sup> Reimbursable health care costs also differ among the States.<sup>79</sup> Finally, in all three States the program is administered by an agency other than the department of insurance.<sup>80</sup>

State-mandated comprehensive health insurance plans in Connecticut, Hawaii, Minnesota, and Wisconsin also differ significantly from the NAIC model and from each other. For example, none of the State plans has the health care cost containment features of the NAIC model.<sup>81</sup> In all the States, benefits vary as do some of the requirements individuals must meet to qualify for State-mandated health insurance.<sup>82</sup> In Connecticut, Minnesota, and Wisconsin, differing legal limits are placed on the

premiums that can be charged.<sup>83</sup> Nevertheless, because the coverage is comprehensive and because the limit can range as high as 150 percent of standard or average premiums, the effect of premium costs can be substantial for individuals.

Among the States, Hawaii is unique. The Hawaii comprehensive plan does not reach insurance carriers; instead it requires that employers provide comprehensive health insurance to full-time employees.<sup>84</sup> People who are not full-time workers or dependents of someone who is employed on a full-time basis are not reached by this law. Hawaii also requires employers to pay half the premiums and provides for State supplements to small employers whose obligation to pay premiums exceeds specified limits.<sup>85</sup> In addition, Hawaii does not provide for a reinsurance mechanism to spread risk and grants oversight authority to the director of labor and industrial relations rather than the commissioner of insurance.<sup>86</sup>

Recent court rulings raise serious questions about the enforceability of State-mandated health insurance plans that relate entirely or partially to employers, employee benefit plans, or self-insured plans. These rulings interpret the applicability of section 514 of the Employee Retirement Income Security Act (ERISA) which provides that all State laws that "relate to" employee benefit plans are superseded.<sup>87</sup> This language is modified by a savings clause that affirms the authority of the States to regulate insurance.<sup>88</sup> However, the savings clause is itself modified by providing that employee benefit plans may not be considered to be in the business of insurance for the purposes of State law.<sup>89</sup> Court decisions have specifically ruled that the Hawaii

Stat. tit. 22, §3185 (1964); Minn. Stat. Ann. §§62E.51-62E.55 (West Supp. 1981), and R.I. Gen. Laws §§42-62-1 to 42-62-22 (1956 and Supp. 1980). The comprehensive health insurance laws appear at Conn. Gen. Stat. Ann. §§38-371 to 38-381 (West Supp. 1981), Haw. Rev. Stat. §§393-1 to 393-51 (1976 and Supp. 1980), Minn. Stat. Ann. §§62E.01-62E.55 (West Supp. 1981), and Wis. Stat. Ann. §§619.10-619.18 (West Supp. 1981-82).

<sup>76</sup> Me. Rev. Stat. tit. 22, §3185 (1964); Minn. Stat. Ann. §§62E.06, 62E.53, and 62E.54 (West Supp. 1981); and R.I. Gen. Laws §§42-62-6 to 42-62-8 and 42-62-18 (Supp. 1980).

<sup>77</sup> Me. Rev. Stat. tit. 22, §3185 (1964); Minn. Stat. Ann. §62E.53 (West Supp. 1981); and R.I. Gen. Laws §42-62-7 (Supp. 1980).

<sup>78</sup> R.I. Gen. Laws §42-62-10 (Supp. 1980).

<sup>79</sup> Me. Rev. Stat. tit. 22, §3185 (1964); Minn. Stat. Ann. §§62E.06 and 62E.53 (West Supp. 1981); and R.I. Gen. Laws §§42-62-6 and 42-62-8 (Supp. 1980).

<sup>80</sup> In Maine the administering agency is the department of human services; in Minnesota, the department of public welfare; and in Rhode Island, the department of health. Me. Rev. Stat. tit. 22,

§3185 (1964); Minn. Stat. Ann. §§62E.52-62E.53 and 62E.54 (West Supp. 1981); and R.I. Gen. Laws §42-62-18 (Supp. 1980).

<sup>81</sup> "Comprehensive Health Insurance and Health Care Cost Containment Model Act," *NAIC Model Laws*, vol. 1, pp. 80-23 to 80-29.

<sup>82</sup> Conn. Gen. Stat. Ann. §§38-371 to 38-375 (West Supp. 1981); Haw. Rev. Stat. §§393-3 to 393-11 and 393-14, 393-15, and 393-17 (1976 and Supp. 1980); Minn. Stat. Ann. §§62E.02, 62E.03, 62E.04, 62E.06, and 62E.14 (West Supp. 1981); and Wis. Stat. Ann. §§619.10, 619.12, and 619.14 (West Supp. 1981-82).

<sup>83</sup> Conn. Gen. Stat. Ann. §38-376 (West Supp. 1981), Minn. Stat. Ann. §62E.08 (West Supp. 1981), and Wis. Stat. Ann. §619.17 (West Supp. 1981-82).

<sup>84</sup> Haw. Rev. Stat. §§393-3 and 393-11 (1976).

<sup>85</sup> Haw. Rev. Stat. §§393-13, 393-15, and 393-45 (1976).

<sup>86</sup> Haw. Rev. Stat. §§393-1 to 393-51 (1976 and Supp. 1980).

<sup>87</sup> 29 U.S.C. §1144(a) (1976).

<sup>88</sup> 29 U.S.C. §1144(b)(2)(A) (1976).

<sup>89</sup> 29 U.S.C. §1144(b)(2)(B) (1976).

**TABLE 3.9**  
**Comparisons of Covered Persons 14 to 64 Years Old With and Without Health Limitations, by Race or Ethnicity and Sex: 1976**

| Race or ethnicity <sup>a</sup> and sex | Total <sup>b</sup>            |  | With health limitation <sup>c</sup> |   | No health limitation          |  |
|--|-------------------------------|--|-------------------------------------|---|-------------------------------|--|
|  | Percent with health insurance |  | Percent with health insurance       | Percent of total with health limitation | Percent with health insurance | Percent of total with no health limitation |
| Majority                               |                               |  |                                     |   |                               |  |
| Males                                  | 90.1                          |  | 83.2                                | 2.0                                     | 90.5                          | 98.0                                       |
| Females                                | 90.3*                         |  | 84.2*                               | 3.1                                     | 90.7*                         | 96.9                                       |
| Black                                  |                               |  |                                     |   |                               |  |
| Males                                  | 79.1                          |  | 64.5                                | 2.7                                     | 80.2                          | 97.3                                       |
| Females                                | 81.1                          |  | 71.3                                | 3.2                                     | 81.9                          | 96.8                                       |
| Hispanic                               |                               |  |                                     |   |                               |  |
| Males                                  | 73.1                          |  | 64.6                                | 2.1                                     | 73.7                          | 97.9                                       |
| Females                                | 74.6                          |  | 65.5                                | 2.3                                     | 75.1                          | 97.7                                       |

<sup>a</sup> There were too few cases to show data for Asian and Pacific Island Americans and American Indians.

<sup>b</sup> Excludes persons covered by medicaid or medicare, receiving supplemental security income (SSI), public assistance, or welfare payments. See appendix A.

<sup>c</sup> Persons with a health limitation have a physical, mental, or emotional condition which restricts or interferes with their ability to do regular school work, take part in sports (persons 14 to 17 only), or work around the house, or which prevents or limits working at a job.

\* The difference between this value and the corresponding value for majority males is not statistically significant at the 0.05 level of confidence. See appendix A for data source and sampling information.

Source: Special tabulations from the Survey of Income and Education, 1976.

plan, which is addressed entirely to employers, and that part of the Minnesota comprehensive health insurance program, which places requirements on employers, are preempted by ERISA and are, therefore, invalid.<sup>90</sup> State law is not preempted, however, when it applies to the products or services provided to an employee benefit plan by a State-regulated insurance company.<sup>91</sup> Nevertheless, many employers now self-insure their employee health benefits program or engage only limited services of insurance carriers in administering benefit programs.<sup>92</sup> Thus, ERISA preemption does impinge on the present scope of coverage possible under State-mandated health insurance.

A national health insurance plan would not face preemption by ERISA and could fill present gaps in insurance coverage without the necessity of State-by-State approval. In these respects, national health insurance offers advantages that State-mandated plans do not. The 1970s, in fact, saw a succession of legislative proposals introduced in the U.S. Congress calling for some form of national health insurance. Although these bills varied widely, they can be broadly categorized into essentially three types:

- Narrow coverage, minimal Federal financial role
- Comprehensive coverage, mixed private and public financial role
- Comprehensive coverage, large Federal financial role<sup>93</sup>

• Catastrophic health insurance is the most common example of the first type. In the 1970s the most prominent proposal of

this genre was a bill sponsored by Rep. Joe Waggoner (D-La.) and Sens. Russell Long (D-La.) and Abraham Ribicoff (D.-Conn.).<sup>94</sup> The bill would have provided health insurance protection beyond a stipulated catastrophic threshold to all U.S. residents.<sup>95</sup> Employers and the self-employed would have had the option of purchasing such coverage through the private market.<sup>96</sup> The unemployed, welfare recipients, older Americans, and others unable to purchase private insurance or who did not exercise this option would have been protected under a federally administered public plan.<sup>97</sup> The public plan would have been financed through a payroll tax.<sup>98</sup>

Numerous bills proffered in Congress fall into the second category. Typically, they provided for fairly comprehensive coverage, although some contained cost-sharing features such as deductibles and copayment requirements.<sup>99</sup> Some also limited coverage for such services as dental and nursing home care.<sup>100</sup> Many called for a two-part program, requiring employers to provide coverage to employees through the private market and providing federally administered or contracted coverage for the poor, medically indigent, and older Americans.<sup>101</sup> Many of these plans also explicitly envisioned a role for States in supervising insurance carriers and medical care providers.<sup>102</sup> Health insurance purchased by employers would have been financed by employer-employee premium payments with some Federal

group coverage in the United States was provided under administrative service only or minimum premium plans arrangements. Under these agreements, employers establish self-insured plans but pay a fee to insurance carriers to process claims or insure against a level of claims that exceeds some large and unusual level. *Source Book*, p. 8.

<sup>93</sup> A similar typology can be found in Judith Feder, John Holahan, and Theodore Marmor, ed., *National Health Insurance: Conflicting Goals and Policy Choices* (Washington, D.C.: Urban Institute, 1980), and Tyrus G. Fain, Katherine C. Plant, and Ross Milloy, ed., *National Health Insurance* (New York: R.R. Bowker Co., 1977).

<sup>94</sup> Feder, Holahan, and Marmor, *National Health Insurance*, p. 3, and Fain, Plant, and Milloy, *National Health Insurance*, pp. 541-548.

<sup>95</sup> *Ibid.*

<sup>96</sup> *Ibid.*

<sup>97</sup> *Ibid.*

<sup>98</sup> *Ibid.*

<sup>99</sup> Feder, Holahan, and Marmor, *National Health Insurance*, pp. 4-6 and Fain, Plant, and Milloy, *National Health Insurance*, pp. 519-540.

<sup>100</sup> *Ibid.*

<sup>101</sup> *Ibid.*

<sup>102</sup> *Ibid.*

<sup>90</sup> *Standard Oil Company of California v. Agsalud*, 442 F. Supp. 695 (N.D. Cal. 1977), *aff'd* 633 F.2d 760 (9th Cir. 1980); *St. Paul Electrical Workers Welfare Fund v. Markman*, 490 F. Supp. 931 (D. Minn. 1980).

<sup>91</sup> *Wadsworth v. Whaland*, 562 F.2d 70 (1st Cir. 1977); *Old Stone Bank v. Michaelson*, 439 F. Supp. 252 (D. R.I. 1977).

<sup>92</sup> Estimates of the percentage of employees covered by self-insured plans vary. A study by the Social Security Administration found that as of 1974 only 6 percent of workers with health care plans were self-insured. Daniel Price, *Private Industry Health Insurance Plans: Type of Administration and Insurer in 1974*, Social Security Administration, HEW Pub. (SSA) 77-11700, reprinted from the *Social Security Bulletin*, March 1977. Later in 1978, a report done by the Wyatt Company for the Department of Labor stated that 23 percent of salaried employees receiving medical benefits were under self-insured plans. Wyatt Company, *1978 Survey of Group Death, Disability and Medical Benefits for Salaried Employees* (report prepared for the U.S. Department of Labor). This differs substantially from the results of a survey by the Wisconsin Insurance Commissioner of the largest employers in that State, which found that over 50 percent of the employees in surveyed companies were covered by self-insured employee plans. Janet Reinke, planning analyst, memorandum to Thomas Nefty, deputy commissioner of insurance for the State of Wisconsin, Feb. 11, 1980. In addition, the Health Insurance Institute estimates that 20 percent of 1979 insurance company

subsidization for low-income workers, the self-employed, and small employers.<sup>103</sup> The federally administered or contracted part of the program usually called for direct Federal payments to insurance companies or medical care providers or for issuance of vouchers or granting of tax credits to qualified individuals who would then use this assistance to purchase insurance in the private market.<sup>104</sup>

The prime example of a national health insurance plan with broad coverage and a substantial Federal role was the bill sponsored throughout much of the 1970s by Sen. Edward Kennedy (D-Mass.) and Rep. James C. Corman (D-Cal.).<sup>105</sup> Their proposal offered comprehensive coverage for the entire U.S. population and contained no cost-sharing features, such as coinsurance or deductibles.<sup>106</sup> The program would have been financed by a Federal payroll tax on earned and unearned income.<sup>107</sup> The Federal Government would not only have been responsible for payment of claims but also for allocation of a national health budget among regions and types of medical services.<sup>108</sup>

One of the most controversial aspects of national health insurance is its potential effect on the Federal budget and total expenditures for health care. As

estimates of the effect on Federal outlays indicate, mixed public-private programs, in which insurance for some segments of the population is financed out of premium payments to private insurers, would minimize the cost to the Federal budget.<sup>109</sup> Total expenditures by consumers, the Federal Government, and other units of government can also be reduced by incorporation of certain cost containment features.<sup>110</sup> Cost containment measures most often mentioned include patient cost sharing (e.g., coinsurance or deductibles) to make the purchaser more cost conscious, utilization controls (i.e., review of the need and quality of care), and controls on reimbursement of hospital charges and health practitioner fees.<sup>111</sup>

The effect of national health insurance on health care costs is an important issue. It is equally important, however, that those persons who cannot effectively be served by the private insurance market alone be provided with adequate health insurance coverage through the intervention of government. Some form of national health insurance is urgently needed to serve the disproportionate number of minorities and women who are currently unable to obtain coverage in the private market.

<sup>103</sup> Ibid.

<sup>104</sup> Ibid.

<sup>105</sup> Feder, Holahan, and Marmor, *National Health Insurance*, pp. 6-7 and Fain, Plant, and Milloy, *National Health Insurance*, pp. 509-18.

<sup>106</sup> Ibid.

<sup>107</sup> Ibid.

<sup>108</sup> Ibid.

<sup>109</sup> Fain, Plant, and Milloy, *National Health Insurance*, pp. 100-5 and 125-64.

<sup>110</sup> Ibid.

<sup>111</sup> Ibid., pp. 165-77 and Feder, Holahan, and Marmor, *National Health Insurance*, pp. 349-73.

## Summary

---

The health insurance industry is economically important both in terms of the employment opportunities and wages it provides and the protection it affords against potentially catastrophic health care costs. However, minorities and women do not share equally with majority men in the benefits derived from working for the industry or in health insurance coverage.

### Employment

In 1979 health insurers (primarily life insurance companies and hospital and medical service plans) had a payroll of \$9.4 billion and employed about 1.3 million people, nearly all of whom were white-collar workers. White-collar work, as Equal Employment Opportunity Commission (EEOC) data show, however, means something different for minorities and women than for majority men. Although women numbered more than half of the insurance industry labor force, over two-thirds were in office and clerical positions. However, during the 1970s, the representation of women in managerial and professional occupations increased from 9.1 percent to 13.4 percent, with a concomitant decrease in the percentage employed as office and clerical workers (78.1 to 67.8 percent). The percentage of women employed as technicians almost doubled from 1973 to 1978, rising most dramatically in insurance firms with Federal contracts. In contrast, no appreciable gains were made in the representation of women in sales jobs. Further, despite gains made in management and the professions, women are still substantially underrepresented in these occupations.

Minority men are not as well represented as majority men in management, professional, and sales positions. For example, a comparatively low percentage of men of all minority racial and ethnic groups are managers. Blacks and Hispanics are underrepresented as professionals and Asian and Pacific Island Americans and American Indians as sales personnel.

Present hiring patterns, promotion rates, and training opportunities are not moving minorities and women rapidly into higher levels of the insurance industry. Industry institutions that provide training for and test the competency of individuals working in the trade do not even keep data on the race and national origin of participants so they can evaluate their effectiveness in reaching minorities.

Federal, State, and local equal employment opportunity agencies have not exercised their enforcement powers with sufficient vigor substantially to affect the participation of minorities and women in the insurance industry. According to data from the Equal Employment Opportunity Commission, little difference exists in the employment patterns of insurance companies that are government contractors, and therefore subject to affirmative action requirements, and firms that are not contractors. Further, U.S. Department of Labor survey data show that wage differences based on sex continue to prevail in the insurance industry.

State insurance departments that have authority to license sales agents do not take advantage of this power to monitor the extent to which minorities and women are entering the sales field, an area where

these agencies might promote employment opportunities. To the contrary, agent licensing examinations administered by insurance departments in some States may be operating to exclude minorities who are interested in becoming insurance agents. In this manner, many insurance departments are not playing a positive role in assuring equal opportunity for sales personnel.

Clearly, insurance companies and related regulatory and training institutions face a long road to achieving greater job opportunities for women and minorities. Much remains to be done in moving women out of secretarial and clerical positions into sales, management, and the professions and in increasing the representation of minorities in these latter occupational categories as well. Appropriate Federal and State regulatory agencies, which seem to have had little effect in changing employment patterns, need to reassess the nature and extent of their enforcement activities. Finally, industry training institutions should, at a minimum, begin to collect and analyze data on the race and ethnic background of program participants for purposes of self-evaluation.

### **Health Insurance Coverage**

Among persons not eligible for medicare or medicaid, about 90 percent of the majority population has private health insurance. In contrast, about 75 percent of Hispanics, 70 percent of American Indians, and 80 percent of blacks and Asian and Pacific Island Americans are insured. Married women are more likely to have health insurance coverage than women who are widowed, divorced, separated, or never married.

This report's statistical analysis of the relatively low insurance coverage rates of minorities and women presents no evidence of intentional discrimination by insurers. Discrimination these groups experience elsewhere, however, affects their health and socioeconomic condition and, given the institutional framework within which insurance underwriting, marketing, and regulation take place, does operate to deny them equal access to insurance. For example, most health insurance is sold on a group basis and is acquired through employment. Because minorities and women have higher unemployment rates than majority men, this avenue of obtaining insurance is available to disproportionately fewer women and racial and ethnic minorities, a fact that can be especially critical during an economic recession.

In addition, other characteristics, such as occupation, industry, income, and full-time or part-time work, are key variables in an insurer's decision to issue health insurance. Minorities and women, because of continuing discrimination in education and employment, are not found in those jobs and income groups fitting the standards set by insurers to the extent majority men are. However, even in those employment and income groups considered to be good risks, minorities and divorced and separated women often are less likely to be insured than majority men. These are potential female and minority markets that the insurance industry can serve but is overlooking.

Again, because most health insurance is sold on a group basis, many young adults, children, and homemakers obtain coverage through some other family member. The relationship of the primary insured becomes the means by which health insurance is acquired or lost. Similar to their adult counterparts, minority children are less likely to be insured than majority children. Family policies that insure children from birth to age 18, or beyond if they remain in school, do not protect children when there is no family coverage. Because divorced and separated women are among the least likely to have health insurance, so also are other members of the families they head. Existing conversion rights, which permit a divorced woman to change from the ex-husband's group policy to an individual policy in her own name, are not an effective means for assuring continuing coverage for herself or her children. Industry marketing practices discourage agents from selling conversion policies, which, when offered, may be prohibitively expensive because the employer no longer shares the premium costs and less expensive group rates are no longer available.

Health status is also related to health insurance coverage. While the purpose of health insurance is to assist people in meeting the possible costs of treating some future illness or injury, some persons with an existing health limitation are considered poor risks by the industry because the likelihood of a future claim is more certain. Thus, people with a health limitation, while most in need of insurance, often must go without it. Among health-limited persons, the absence of any coverage is more common among blacks and Hispanics than majority persons. However, even among those without a health limitation, insurance coverage rates are relatively lower for minorities.

Health insurance is an essential service that helps pay the often high costs of treatment for an illness or injury, and private insurers play an important role in meeting these personal health care expenditures. As the descriptive analysis contained in this report shows, minorities and women who are not medicaid or medicare eligibles are often substantially less likely to have private health insurance than their majority male counterparts. These disparities cannot be ignored. The comparatively low rates of insurance coverage among minorities and women who are in good health and essentially in the economic mainstream indicate a potential clientele that the insurance industry can serve without jeopardizing financial solvency. The profitability of this market has been overlooked for lack of adequate information and experience in serving this group.

For persons with health and socioeconomic characteristics that make them less desirable or unacceptable risks in the private market, better public means of economic protection against health care costs are needed. A few States have mandated either catastrophic or comprehensive health insurance programs, which represent one alternative for filling this need. These plans, however, cover only the residents of the States that have instituted programs. In addition, current Federal law limits the application of State insurance requirements to self-insured employee benefit plans. Unless States are willing on a widespread basis to enact mandated health insur-

ance protection and conflicts with Federal law are overcome, national health insurance represents an alternative that would provide more universal coverage. Several national health insurance proposals have, in fact, been introduced and discussed in the U.S. Congress in the recent past. These include bills providing for either catastrophic or comprehensive coverage. Some would minimize the effect on the Federal budget by utilizing mixed public and private financing. Some would also curtail inflationary pressures that national health insurance would have on total health care expenditures by instituting significant cost containment programs. Most would make substantial inroads in filling present gaps in insurance coverage for persons who are unable to obtain private insurance policies.

Today, those who are not insured either must suffer needless pain or early death because health care costs too much or they must face financial disaster when stricken with a serious illness. A disproportionate number of those who live with these undesirable alternatives are minorities and women. Their plight cannot go unheeded. Congress should rededicate itself to the task of passing national health insurance legislation that meets the needs of these individuals while safeguarding the national economy by providing for an appropriate role for the private insurance industry and instituting workable cost containment measures.

## Appendix A

### Methodology

---

#### Employment of Minorities and Women in the Insurance Industry

The analysis of the occupational status and participation rates of minorities and women in the insurance industry was based on data furnished by private employers in 1973 and 1978 to the Equal Employment Opportunity Commission (EEOC) on EEO-1 forms. By law, every private employer with more than 50 employees or every firm with more than one base of operations with 25 employees in each is required to complete and file an EEO-1 form. The data analyzed in this report are for life, accident, and health insurance firms, as well as hospital and medical service plan firms (standard industrial classification codes 631 and 632). Companies listed under SIC code 631 sell other lines of insurance in addition to health insurance. Unfortunately, EEOC data are not reported in such a way to enable examination of employment in that part of the work force engaged in selling and servicing health insurance. Data for 1973 and 1978 are for the identical companies. Insurers that could not be matched for both years were excluded from the analysis. Thus, changes in occupational status and participation rates discussed in this report are for the same set of firms and are not

affected by any entry or exit of firms in the industry that may have occurred between 1973 and 1978.

#### Estimates of the Uninsured Population

A number of independent surveys conducted in 1976 indicated that 12 to 13 percent of the under-65 population (approximately 24 million persons) were without any type of health insurance coverage. One of these was undertaken by the Center for Health Administration Studies and the National Opinion Research Center (CHAS-NORC) at the University of Chicago and indicated that 12 percent of persons under 65 were without coverage, although some of these individuals may have veterans benefits.<sup>1</sup> Figures from the Survey of Income and Education (SIE) showed that approximately 13 percent of all under-65 individuals were without insurance coverage. This estimate was derived from special tabulations created from the SIE for this report. The 1976 Health Interview Survey (HIS) results also indicated a similar (12 percent) noninsurance rate for persons under 65 years of age.<sup>2</sup>

Data available from the National Medical Care Expenditure Survey (NMCES) indicate that in 1977 approximately 13.5 percent of persons under the age of 65 were without health insurance coverage.<sup>3</sup>

<sup>1</sup> Lu Ann Aday, Ronald Andersen, and Gretchen Fleming, *Health Care in the U.S.: Equitable for Whom?* (Beverly Hills: Sage Publications, 1980), p. 80.

<sup>2</sup> U.S., Department of Health, Education, and Welfare, National Center for Health Statistics, *Health Care Coverage: United States,*

1976, *Advance Data*, no. 44 (Sept. 20, 1979), p. 3 (hereafter cited as *Health Care Coverage*).

<sup>3</sup> U.S., Department of Health and Human Services, Public Health Service, National Center for Health Services Research,



More recent results from the 1978 Health Interview Survey estimate that approximately 12.3 percent of the under-65 population was uninsured by private health insurance, medicaid (including those eligible), medicare, or military or veterans benefits.<sup>4</sup> Other studies have estimated a greater degree of insurance coverage among the population. A study sponsored by Roche Laboratories estimated that over 94 percent of the population was covered by public or private health benefits. Because duplicate insurance coverage was not taken into account, however, this estimate is probably somewhat high.<sup>5</sup> Another study, conducted by the Congressional Budget Office, estimated that 5 to 8 percent of the U.S. population had no health care coverage in calendar year 1978. These figures were derived from SIE data adjusted on the basis of medicaid, medicare, and Veterans Administration (VA) program reporting information. Using demographic and income characteristics, this adjustment imputed medicaid, medicare and VA coverage to selected persons who reported having no health insurance.<sup>6</sup>

### Data Source and Sampling Information for the Survey of Income and Education

The health insurance coverage rate data presented in chapter 3 are derived from a special data file created from the public use sample tapes of the 1976 Survey of Income and Education. This data source was selected because it represents the most recent survey for which public-use data are available on health insurance coverage and because this nationally based survey consists of samples large enough to provide statistically reliable data on insurance coverage cross-tabulated by race or ethnicity and sex. Unless otherwise specified, the data presented in chapter 3 exclude persons 65 years of age and older. Throughout the report, the same operational definitions of the following population groups are used:

*Who Are the Uninsured*, Data Preview 1, National Health Care Expenditures Study (1980), p. 2, table 1.

<sup>4</sup> U.S., Department of Health and Human Services; National Center for Health Statistics, *Health Care Coverage Under Private Health Insurance, Medicare, Medicaid, and Military or Veterans Administration Health Benefits: United States, 1978*, no. 71 (June 29, 1981), table 1, p. 2.

<sup>5</sup> Stephen G. Sudovar and Kathleen Sullivan, *National Health Insurance Issues: The Unprotected Population* (New York: Roche Laboratories, 1977), pp. 3, 10-11.

<sup>6</sup> U.S., Congress, Congressional Budget Office, *Profile of Health Care Coverage: The Haves and Have-Nots* (March 1979), pp. 4 and 7-12 (hereafter cited as *Haves and Have-Nots*).

- Black—Includes persons whose race was defined as black or Negro. This category, however, does not include blacks of Hispanic origin.
- Hispanic—Includes persons of any race who identified themselves or were identified by another member of the household as Mexican American, Chicano, Mexican, Mexicano, Puerto Rican, Cuban, Central or South American, other Spanish, or Portuguese.
- Asian and Pacific Island American—Includes persons of Japanese, Chinese, Filipino, Korean, or Vietnamese origin.
- American Indian—Includes persons of North American Indian or Eskimo origin.
- Majority—Includes all persons not elsewhere classified. All majority persons are identified as "white" by race. However, the majority category is not equivalent to the "white" category as used in Census publications, since white Hispanics are excluded from the former group and included in the latter.

Because these categories are defined to be mutually exclusive, a single individual can be a member of only one category.

### The Survey of Income and Education

The SIE is the largest available demographic-socioeconomic survey conducted between the 1970 and 1980 censuses, containing information from 151,170 households interviewed predominantly in May and June of 1976.<sup>7</sup> The survey was conducted by the Bureau of the Census acting as collection agent for the Department of Health, Education, and Welfare, primarily to collect accurate income information for each State and the District of Columbia. The survey covers the civilian noninstitutional population of the United States and members of the Armed Forces living with their families onpost or offpost.<sup>8</sup>

<sup>7</sup> U.S., Department of Commerce, Bureau of the Census, *Data Access Descriptions, Microdata from the Survey of Income and Education*, no. 42 (January 1978), p. 1. This publication provides a detailed description of the sampling methods and weighting procedures used in conjunction with the SIE.

<sup>8</sup> U.S., Department of Commerce, Bureau of the Census, *Demographic, Social, and Economic Profile of States: Spring 1976*, Current Population Reports, series P-20, no. 334 (January 1979), p. 101 (hereafter cited as *Profile of States*). U.S., Department of Commerce, Bureau of the Census, *Money Income and Poverty Status in 1975 of Families and Persons in the United States and the West Region, by Divisions and States*, Current Population Reports, series P-60, no. 113 (July 1978), p. 2 (hereafter cited as *Money*

The SIE sample design consists of a stratified multistage cluster sample, based in part on the proportion of persons in each State who were children 5 to 17 living in poverty in 1970.<sup>9</sup> The weight given each interview on the public-use tapes was determined through a series of ratio-estimation procedures whereby preliminary weights were adjusted to reflect independently derived national estimates for various age, race, residence, and sex categories.<sup>10</sup> Thus, the sample was representative of the total population. The basic sample design, in conjunction with the ratio-estimation procedures, reduced the statistical error of the survey estimates below what would be expected by simply weighing each interview by the inverse of the probability of selection.

The SIE data presented in chapter 3 are derived from special Commission public use tapes where, for reasons of economy, one in eight majority persons was randomly selected for inclusion on the tapes. This was done to equalize more nearly the number of unweighted cases representing each of the five racial/ethnic categories, so that final estimates of comparative insurance coverage rates could be made with somewhat less expense. In the creation of these tapes, quality checks revealed no subsample weaknesses.<sup>11</sup> These tapes have also been used as the basis for data analysis in other Commission reports.<sup>12</sup> The final number of unweighted cases representing persons under 65 years of age in each race and ethnic category is as follows: majority 39,120; black 23,000; Hispanic 13,015; Asian and Pacific Island American 4,907; American Indian 2,608. See appendix table A.2 for the number of unweighted cases used to calculate estimates of insurance coverage rates shown in text tables, figures, and appendix tables B.3, B.4, and B.6. These unweighted totals were also used to calculate tests of significance. In no case was an insurance coverage rate shown in the tables if the base of the calculation consisted of fewer than 50 unweighted cases because it was thought they would be subject to an unacceptable degree of sampling variability.

The percentages derived from the SIE tapes were calculated from weighted totals. In other words, the

assigned weights were used to inflate the unweighted number of cases to national totals, and percentages were subsequently calculated. Thus, the percentage of Hispanics with health insurance coverage, for example, was computed from totals that closely approximated the total Hispanic population in the United States and the total number with health insurance. Members of the majority were given eight times the assigned weights to preserve the integrity of the original sampling design, given the one in eight sample of the majority population. Where possible, the weighted totals were checked with published data from the SIE before percentages were calculated.<sup>13</sup> Given the different definitions of certain racial and ethnic categories and the sampling of the majority population, the tabulated and published figures were comparable.

As the primary focus of chapter 3 was to delineate differences in *private* insurance coverage rates of majority males, women, and minorities, it was necessary to eliminate persons covered by medicaid or similar public insurance programs. To include persons covered by public insurance programs as "covered" would tend to increase the percentage of persons in all categories who report having health insurance. (See appendix table A.1.) Further, these percentages would tend to obscure the measurement of how effective the private insurance industry is in providing insurance to female family heads and racial and ethnic minorities. In effect, eliminating all persons covered by public health insurance programs from the calculation of percentages allows a closer focus on the population most "at risk" in acquiring private health insurance coverage.

However, simply to omit persons who reported being covered by medicare or medicaid or similar programs would underestimate considerably the number of persons who are eligible for such programs. Surveys such as the SIE tend to underestimate the actual number of insured and eligible people because survey respondents sometimes are unaware of—or do not remember—their eligibility for particular benefits or may be reluctant to reveal it.<sup>14</sup> Program data, while somewhat more inclusive, may still be inaccurate or difficult to interpret. Little

*Income*). *Profile of States*, p. 92. American Indians living on reservations were included in the sampled population.

<sup>9</sup> *Money Income*, p. 193.

<sup>10</sup> *Ibid.*, pp. 194-95.

<sup>11</sup> U.S., Commission on Civil Rights, *Social Indicators of Equality for Minorities and Women* (August 1978), appendix C, p. 109 (hereafter cited as *Social Indicators*).

<sup>12</sup> See *Social Indicators* and U.S., Commission on Civil Rights, *Unemployment and Underemployment Among Blacks, Hispanics, and Women*, forthcoming.

<sup>13</sup> Data from *Profile of States* and *Money Income* were used to check independently derived SIE figures.

<sup>14</sup> *Have and Have-Nots*, pp. 4-5.

information is available concerning the manner in which the States count medicaid recipients, and it is speculated that these counts may contain substantial duplication.<sup>15</sup> Data from the SIE show that approximately 8,700,000 persons reported receiving medicaid in spring of 1976. In fiscal 1976, program data estimated that approximately 25 million persons received services paid for by medicaid,<sup>16</sup> almost three times the number who reported being covered by medicaid through the SIE. It is a reasonable assumption that the actual number of medicaid recipients and eligibles lies somewhere between program and survey estimates.

One way to achieve a better estimate of the number of public insurance eligibles is to eliminate from the calculation of insurance coverage rates those persons who actually reported receiving medicaid or medicaid as well as those who would most likely be eligible for such coverage through the receipt of public assistance.<sup>17</sup> The following criteria were used to determine which persons would most likely be eligible for public insurance programs and, therefore, should be omitted from subsequent calculations. If a person answered yes to one or more of the following six questions, the individual was eliminated from the tabulations. For persons in families, if anyone in the family answered yes to one or more of the following questions, all persons in the family were excluded from subsequent calculations:

1. Covered by medicaid health insurance?
2. Covered by medicare health insurance?
3. Received benefits or services in the past year from medicaid?
4. Total family income for 1975 included \$1.00 or more from Federal or local supplementary security income?

5. Total family income for 1975 included \$1.00 or more public assistance or welfare income from the State or local welfare office?

6. Received any money from public assistance or welfare from the State or local welfare office, last month?

A total of 21,192,800 persons aged 0 to 64 were excluded from the final tabulations using the above criteria. This figure is considerably higher than the number of medicaid recipients indicated by the SIE but, given the somewhat inflated program estimates of medicaid eligibles (25 million persons), appears to be a reasonable estimate. The new weighted estimates (excluding the 21,192,800 persons selected out through the above criteria) upon which the tabular percentages were based are shown in appendix table A.1. Comparative figures including the estimated 21.2 million public insurance recipients and eligibles are also shown.

These numbers, as well as the percentages shown in the tables and text of chapter 3, are based upon samples from populations rather than upon interviews covering the entire population. As such, the percentages are estimates of health insurance coverage rather than exact measurements of the incidence of such coverage. These estimates, unlike exact measurements, are subject to error to the degree that the sample does not precisely reflect the incidence of health insurance coverage within the sampled universe. Tests of significance can be used, however, to determine whether or not the observed differences between two samples selected from separate populations fall within a previously agreed-upon margin of error.

All comparisons of health insurance coverage rates derived from the SIE data were subject to a two-sample test of proportions, using a five percent

<sup>15</sup> *Health Care Coverage*, p. 5.

<sup>16</sup> *Ibid.*

<sup>17</sup> Medicaid eligibility is automatically conferred on almost all recipients of cash payments under the aid to families with dependent children (AFDC) and supplemental security income (SSI) programs. *Haves and Have-Nots*, p. 7. See the discussion and methodology in *Haves and Have-Nots*, pp. 4-14, for an alternate method of estimating medicaid eligibles using SIE data.

**TABLE A.1****Population Under 65 Without Health Insurance, Based on Inclusion and Exclusion of Public Insurance Recipients, and on Race or Ethnicity: 1976**

| Race or ethnicity                        | Total                  | Total without insurance | Percentage without insurance |
|--|------------------------|-------------------------|------------------------------|
|  | (numbers in thousands) |                         |                              |
| Majority                                 |                        |                         |                              |
| Inc. public ins. recipients <sup>a</sup> | 153,507                | 15,847                  | 10.3                         |
| Ex. public ins. recipients <sup>b</sup>  | 142,533                | 13,525                  | 9.5                          |
| Black                                    |                        |                         |                              |
| Inc. public ins. recipients              | 22,382                 | 5,133                   | 22.9                         |
| Ex. public ins. recipients               | 14,863                 | 3,072                   | 20.7                         |
| Hispanic                                 |                        |                         |                              |
| Inc. public ins. recipients              | 10,721                 | 2,904                   | 27.1                         |
| Ex. public ins. recipients               | 8,418                  | 2,219                   | 26.4                         |
| Asian & Pacific Island American          |                        |                         |                              |
| Inc. public ins. recipients              | 1,890                  | 347                     | 18.3                         |
| Ex. public ins. recipients               | 1,759                  | 325                     | 18.5                         |
| American Indian                          |                        |                         |                              |
| Inc. public ins. recipients              | 1,126                  | 417                     | 37.0                         |
| Ex. public ins. recipients               | 860                    | 280                     | 32.6                         |
| Total                                    |                        |                         |                              |
| Inc. public ins. recipients              | 189,626                | 24,648                  | 13.0                         |
| Ex. public ins. recipients               | 168,433                | 19,421                  | 11.5                         |

<sup>a</sup> Includes persons covered by medicaid or medicare, receiving supplemental security income (SSI), public assistance, or welfare payments.

<sup>b</sup> Excludes persons covered by medicaid or medicare, receiving supplemental security income (SSI), public assistance, or welfare payments.

Source: Special tabulations from the Survey of Income and Education, 1976.

**TABLE A.2****Number of Unweighted Cases Used to Calculate Rates of Insurance Coverage in Text, Appendix Tables, and Figures**

| Population | Text table | Subject   | Majority | Black | Hispanic | Asian & Pacific Island American | American Indian |
|------------|------------|---|----------|-------|----------|---------------------------------|-----------------|
| Males      | 3.1        | Total 14 to 64                                      | 14,559   | 8,019 | 4,097    | 1,814                           | 978             |
| Females    |            |   | 14,988   | 8,441 | 4,166    | 2,160                           | 999             |
| Males      |            | Employed  | 11,722   | 5,436 | 3,076    | 1,403                           | 663             |
| Females    |            |   | 7,826    | 4,815 | 1,940    | 1,304                           | 443             |
| Males      |            | Unemployed  | 661      | 741   | 280      | 109                             | 91              |
| Females    |            |   | 671      | 750   | 259      | 89                              | 75              |
| Males      |            | Not in labor force                                  | 1,899    | 1,581 | 644      | 256                             | 183             |
| Females    |            |   | 6,491    | 2,876 | 1,967    | 767                             | 481             |
| Males      | 3.2        | Professional and technical                          | 1,788    | 455   | 287      | 308                             | 53              |
| Females    |            |   | 1,295    | 708   | 167      | 228                             | *               |
| Males      |            | Managers and administrators                         | 1,780    | 337   | 221      | 204                             | 59              |
| Females    |            |   | 480      | 160   | 72       | 60                              | *               |
| Males      |            | Sales   | 725      | 125   | 96       | 52                              | *               |
| Females    |            |   | 554      | 101   | 103      | 91                              | *               |
| Males      |            | Clerical  | 658      | 472   | 166      | 113                             | *               |
| Females    |            |   | 2,735    | 1,363 | 596      | 420                             | 146             |
| Males      |            | Craftsworkers                                       | 2,459    | 836   | 644      | 239                             | 181             |
| Females    |            |   | 128      | 70    | *        | *                               | *               |
| Males      |            | Operatives, ex. transport                           | 1,148    | 913   | 497      | 89                              | 85              |
| Females    |            |   | 689      | 660   | 384      | 126                             | 55              |
| Males      |            | Transport equip. operatives                         | 656      | 555   | 205      | 53                              | *               |
| Females    |            |   | 52       | *     | *        | *                               | *               |
| Males      |            | Nonfarm laborers                                    | 880      | 737   | 359      | 90                              | 102             |
| Females    |            |   | 100      | 53    | *        | *                               | *               |
| Males      |            | Private household workers                           | *        | *     | *        | *                               | *               |
| Females    |            |   | 263      | 375   | 100      | *                               | *               |
| Males      |            | Service, ex. private household                      | 866      | 883   | 433      | 193                             | 74              |
| Females    |            |   | 1,370    | 1,264 | 408      | 299                             | 109             |
| Males      |            | Farm laborers                                       | 288      | 96    | 145      | *                               | *               |
| Females    |            |   | 103      | *     | *        | *                               | *               |
| Males      | 3.3        | Agriculture   | 889      | 160   | 221      | 79                              | 53              |
| Females    |            |   | 205      | *     | 51       | *                               | *               |
| Males      |            | Construction  | 1,164    | 428   | 327      | 105                             | 115             |
| Females    |            |   | 104      | *     | *        | *                               | *               |
| Males      |            | Manufacturing, durable goods                        | 1,763    | 996   | 436      | 83                              | 83              |
| Females    |            |   | 536      | 286   | 162      | *                               | *               |
| Males      |            | Manufacturing, nondurable goods                     | 1,075    | 578   | 309      | 119                             | *               |
| Females    |            |   | 588      | 441   | 246      | 108                             | *               |
| Males      |            | Transportation, communication, and public utilities | 977      | 598   | 240      | 102                             | 70              |
| Females    |            |   | 281      | 178   | 79       | *                               | *               |
| Males      |            | Wholesale trade                                     | 631      | 196   | 114      | 61                              | *               |
| Females    |            |   | 192      | *     | *        | *                               | *               |
| Males      |            | Retail trade  | 1,699    | 597   | 460      | 269                             | 63              |
| Females    |            |   | 1,687    | 516   | 381      | 313                             | 73              |
| Males      |            | Finance, insurance and real estate                  | 479      | 177   | 72       | 67                              | *               |
| Females    |            |   | 572      | 238   | 106      | 100                             | *               |
| Males      |            | Business and repair ser-                            | 444      | 197   | 150      | *                               | *               |

**TABLE A.2 cont'd.**

| Population          | Text table | Subject                     | Majority | Black | Hispanic | Asian & Pacific Island American | American Indian |
|---------------------|------------|-----------------------------|----------|-------|----------|---------------------------------|-----------------|
| Females             |            | vices                       | 187      | 94    | 56       | *                               | *               |
| Males               |            | Private household ser-      | 83       | *     | *        | *                               | *               |
| Females             |            | vices                       | 275      | 391   | 102      | *                               | *               |
| Males               |            | Personal services, ex. pri- | 197      | 147   | 104      | 61                              | *               |
| Females             |            | vate household              | 359      | 270   | 124      | 101                             | *               |
| Males               |            | Professional services       | 1,319    | 692   | 275      | 225                             | 66              |
| Females             |            |                             | 2,369    | 1,773 | 476      | 385                             | 156             |
| Males               |            | Public administration       | 685      | 535   | 222      | 154                             | 80              |
| Females             |            |                             | 355      | 494   | 82       | 87                              | *               |
| Males               | 3.4        | Income under \$5,000        | 864      | 906   | 462      | 150                             | 173             |
| Females             |            |                             | 1,213    | 1,237 | 532      | 171                             | 207             |
| Males               |            | \$5,000 to \$9,999          | 2,117    | 2,027 | 1,029    | 177                             | 225             |
| Females             |            |                             | 2,513    | 2,315 | 1,140    | 305                             | 208             |
| Males               |            | \$10,000 to \$14,999        | 3,177    | 2,048 | 1,213    | 297                             | 235             |
| Females             |            |                             | 3,216    | 1,999 | 1,106    | 391                             | 235             |
| Males               |            | \$15,000 and over           | 8,401    | 3,038 | 1,393    | 1,190                           | 345             |
| Females             |            |                             | 8,046    | 2,890 | 1,388    | 1,293                           | 349             |
| Males               | 3.5        | Age 14 to 18                | 2,297    | 1,478 | 727      | 197                             | 155             |
| Females             |            |                             | 2,188    | 1,400 | 719      | 223                             | 163             |
| Males               |            | Age 19 to 24                | 2,330    | 1,352 | 737      | 282                             | 197             |
| Females             |            |                             | 2,301    | 1,354 | 773      | 330                             | 215             |
| Males               |            | Age 25 to 34                | 3,243    | 1,756 | 1,029    | 459                             | 256             |
| Females             |            |                             | 3,236    | 1,933 | 1,065    | 573                             | 243             |
| Males               |            | Age 35 to 44                | 2,363    | 1,341 | 721      | 300                             | 179             |
| Females             |            |                             | 2,445    | 1,463 | 755      | 415                             | 179             |
| Males               |            | Age 45 to 54                | 2,395    | 1,211 | 596      | 336                             | 110             |
| Females             |            |                             | 2,539    | 1,350 | 574      | 379                             | 120             |
| Males               |            | Age 55 to 64                | 1,931    | 881   | 287      | 240                             | 81              |
| Females             |            |                             | 2,279    | 941   | 280      | 240                             | 79              |
| Females             | 3.6        | Married                     | 9,778    | 4,170 | 2,691    | 1,444                           | 612             |
| Females             |            | Widowed                     | 557      | 518   | 123      | 73                              | *               |
| Females             |            | Divorced                    | 685      | 570   | 173      | 76                              | 63              |
| Females             |            | Separated                   | 153      | 557   | 72       | *                               | *               |
| Females             |            | Never married               | 3,815    | 2,626 | 1,107    | 547                             | 262             |
| Male family heads   | Fig. 3.2   | Total                       | 9,249    | 4,104 | 2,488    | 1,090                           | 568             |
| Female family heads |            | Total                       | 728      | 1,205 | 272      | 94                              | 89              |
| Male family heads   | 3.7        | Employed                    | 8,315    | 3,476 | 2,186    | *                               | *               |
| Female family heads |            |                             | 543      | 984   | 192      | *                               | *               |
| Male family heads   |            | Unemployed                  | 221      | 188   | 120      | *                               | *               |
| Female family heads |            |                             | *        | 70    | *        | *                               | *               |
| Male family heads   |            | Not in labor force          | 478      | 233   | 108      | *                               | *               |

**TABLE A.2 cont'd.**

| Population          | Text table | Subject                     | Majority | Black | Hispanic | Asian & Pacific Island American | American Indian |
|---------------------|------------|-----------------------------|----------|-------|----------|---------------------------------|-----------------|
| Female family heads |            | Not in labor force          | 148      | 151   | 65       | *                               | *               |
| Children (0 to 13)  | 3.8        | Total                       | 9,573    | 6,540 | 4,752    | 933                             | 631             |
| Children            |            | Family income under \$5,000 | 506      | 865   | 438      | 82                              | 161             |
| Children            |            | \$5,000 to \$9,999          | 1,441    | 1,948 | 1,330    | 117                             | 155             |
| Children            |            | \$10,000 to \$14,999        | 2,609    | 1,694 | 1,504    | 163                             | 137             |
| Children            |            | \$15,000 and over           | 5,017    | 2,033 | 1,480    | 571                             | 178             |
| Males               | 3.9        | With health limitation      | 288      | 199   | 87       | *                               | *               |
| Females             |            |                             | 456      | 298   | 102      | *                               | *               |
| Males               |            | No health limitation        | 14,208   | 7,740 | 3,985    | *                               | *               |
| Females             |            |                             | 14,465   | 8,073 | 4,044    | *                               | *               |
| Males               | App. B.3   | Private workers             | 8,593    | 3,881 | 2,359    | 971                             | 438             |
| Females             |            |                             | 5,617    | 3,068 | 1,474    | 930                             | 244             |
| Males               |            | Government workers          | 1,729    | 1,291 | 527      | 313                             | 168             |
| Females             |            |                             | 1,612    | 1,633 | 368      | 308                             | 165             |
| Males               |            | Self-employed workers       | 1,340    | 255   | 185      | 119                             | 56              |
| Females             |            |                             | 428      | 100   | 67       | *                               | *               |
| Males               | App. B.4   | Employed full time          | 10,433   | 4,845 | 2,754    | 1,238                           | 580             |
| Females             |            |                             | 5,291    | 3,779 | 1,417    | 978                             | 340             |
| Males               |            | Employed part time          | 1,289    | 591   | 322      | 165                             | 83              |
| Females             |            |                             | 2,535    | 1,036 | 523      | 326                             | 103             |
| Children            | App. B.6   | Under 1                     | 574      | 367   | 324      | 73                              | *               |
| Children            |            | 1 to 5                      | 2,966    | 2,032 | 1,696    | 321                             | 217             |
| Children            |            | 6 to 13                     | 6,033    | 4,141 | 2,732    | 539                             | 376             |

\* Fewer than 50 cases in unweighted sample.

level of statistical significance.<sup>18</sup> In the great majority of comparisons, the percentage of majority men with insurance coverage was used as the benchmark value against which similar percentages for women and minority groups were compared.<sup>19</sup> The results of these statistical tests are indicated in each text table included in chapter 3. In addition, each implied or direct statistical comparison stated in the text was tested and found to be statistically significant at the 0.05 level.<sup>20</sup> Statistical significance means that one would expect repeated random samples of equal size to yield differences as large as the observed differences less than 5 percent of the time, if there were no true differences in health insurance coverage between the two sampled populations. In other words, there is a 95 percent chance that the observed sample differences reflect actual differences in health insurance coverage of the two populations being compared and a 5 percent chance that these differences do not reflect "true" differ-

ences at all because samples rather than complete counts were used.

The degree of validity attributed to a particular set of data, however, does not evolve strictly from results of tests of significance. The sample design and ratio-estimation weighting procedures of the SIE, for example, increase the representativeness of the samples and add greater reliability to the estimates than would be expected given the sample size alone. In addition, computing health insurance coverage rates for 10 different groups<sup>21</sup> provides a wider context of information than is usually available through tests of significance alone. The fact that similar patterns of health insurance coverage exist when controlling for several variables also provides additional validity to the interpretation of the differences in health insurance coverage that exist between population groups. Further, independent estimates of insurance coverage from 1976 Health Interview Survey data also point to the same general relationships regarding health insurance coverage.<sup>22</sup>

<sup>18</sup> A two-tailed test of significance was used to confirm or deny the null hypothesis that the percentage of majority males with health insurance was the same as the percentage shown for other groups ( $H_0 : P_1 = P_2$ ). At the 0.05 level of statistical confidence, the hypothesis would be rejected if the standard score was  $\geq 1.96$  or  $\leq -1.96$ . The following formulas were used to compute the standard score:

Pooled estimates of P and Q:

$$P = \frac{N_1P_1 + N_2P_2}{N_1 + N_2}$$

$$q = 1 - p$$

Standard error of the difference:

$$s_{(p_1 - p_2)} = \sqrt{pq \left( \frac{1}{N_1} + \frac{1}{N_2} \right)}$$

Standard score:

$$z = \frac{P_1 - P_2}{s_{(p_1 - p_2)}}$$

Note: Unweighted sample sizes (Ns) as shown in table A.1 were used to compute standard scores.

Herman J. Loether and Donald G. McTavish, *Inferential Statistics for Sociologists, An Introduction* (Boston: Allyn and Bacon, 1974), p. 192.

<sup>19</sup> In some tables, comparisons were made with majority women. See the notes at the bottom of each table.

<sup>20</sup> In those situations where a single component of an overall statement is not statistically significant, an indication is made in the footnotes.

<sup>21</sup> In most cases, percentages were computed for each of the five racial or ethnic groups defined above, by sex.

<sup>22</sup> As part of this study, independent computer tabulations of rates of health insurance coverage were made from the 1976 Health Interview Survey. Given differences in sample design, wording of the health insurance question(s), and weighting procedures, the HIS rates substantially reflected the results of the SIE.



## **Appendix B**

### **Appendix Tables to Chapter 3**

---

**TABLE B.1**  
**Percentage Distribution of Employed Persons 14 to 64 Years Old by Occupation, Race or Ethnicity, and Sex: 1976**

| Race or ethnicity and sex          | Occupation <sup>a</sup> |                                    |  |       |          |                    |                                      |                                      |                     |                                 |   |                  |
|------------------------------------|-------------------------|------------------------------------|--|-------|----------|--------------------|--------------------------------------|--------------------------------------|---------------------|---------------------------------|---|------------------|
|                                    | Total <sup>b</sup>      | Profession-<br>al and<br>technical | Manag-<br>ers and<br>adminis-<br>trators | Sales | Clerical | Crafts-<br>workers | Operatives,<br>except trans-<br>port | Transport<br>equipment<br>operatives | Nonfarm<br>laborers | Private<br>household<br>workers | Service, ex-<br>cept private<br>household | Farm<br>laborers |
| Majority                           |                         |                                    |  |       |          |                    |                                      |                                      |                     |                                 |   |                  |
| Males                              | 100.0                   | 16.0                               | 15.3                                     | 6.7   | 6.2      | 20.8               | 10.3                                 | 5.7                                  | 7.2                 | 0.2                             | 7.3                                       | 1.6              |
| Females                            | 100.0                   | 17.2                               | 6.7                                      | 7.0   | 35.6     | 1.8                | 9.2                                  | 0.6                                  | 1.3                 | 3.2                             | 15.9                                      | 1.0              |
| Black                              |                         |                                    |  |       |          |                    |                                      |                                      |                     |                                 |   |                  |
| Males                              | 100.0                   | 8.3                                | 6.2                                      | 2.5   | 8.2      | 14.9               | 17.3                                 | 10.8                                 | 13.1                | 0.1                             | 15.9                                      | 2.2              |
| Females                            | 100.0                   | 14.6                               | 3.3                                      | 2.3   | 27.4     | 1.4                | 14.9                                 | 0.5                                  | 1.1                 | 7.8                             | 25.6                                      | 1.1              |
| Hispanic                           |                         |                                    |  |       |          |                    |                                      |                                      |                     |                                 |   |                  |
| Males                              | 100.0                   | 8.6                                | 7.7                                      | 3.4   | 5.9      | 19.9               | 17.6                                 | 6.3                                  | 10.9                | —                               | 14.4                                      | 4.6              |
| Females                            | 100.0                   | 7.8                                | 3.3                                      | 4.4   | 31.3     | 1.4                | 23.9                                 | 0.2                                  | 1.6                 | 5.5                             | 18.2                                      | 2.3              |
| Asian & Pacific<br>Island American |                         |                                    |  |       |          |                    |                                      |                                      |                     |                                 |   |                  |
| Males                              | 100.0                   | 25.5                               | 17.3                                     | 2.8   | 7.5      | 12.5               | 6.0                                  | 3.1                                  | 4.9                 | 0.5                             | 15.0                                      | 1.9              |
| Females                            | 100.0                   | 22.8                               | 4.4                                      | 5.6   | 27.2     | 1.8                | 12.5                                 | 0.2                                  | 0.8                 | 3.7                             | 19.6                                      | 1.6              |
| American Indian                    |                         |                                    |  |       |          |                    |                                      |                                      |                     |                                 |   |                  |
| Males                              | 100.0                   | 7.1                                | 10.0                                     | 2.8   | 4.7      | 28.7               | 16.8                                 | 6.8                                  | 12.5                | —                               | 7.7                                       | 1.1              |
| Females                            | 100.0                   | 8.8                                | 5.0                                      | 2.9   | 33.9     | 2.1                | 20.6                                 | 1.2                                  | 1.1                 | 3.0                             | 17.9                                      | 2.5              |

<sup>a</sup> There were too few cases to show data for the occupation of farmers and farm managers. As a result, occupations shown will not add to 100 percent.

<sup>b</sup> Excludes persons covered by medicaid or medicare, receiving supplemental security income (SSI), public assistance, or welfare payments. See appendix A.

— Rounds to less than 1 percent.

Source: Special tabulations from the Survey of Income and Education, 1976.

**TABLE B.2****Percentage Distribution of Employed Persons 14 to 64 Years Old by Industry, Race or Ethnicity, and Sex: 1976**

| Race or ethnicity and sex       | Industry <sup>a</sup> |             |              |                              |                                 |   |                 |              |                                     |                              |                            |   |                       |                       |
|---------------------------------|-----------------------|-------------|--------------|------------------------------|---------------------------------|---|-----------------|--------------|-------------------------------------|------------------------------|----------------------------|---|-----------------------|-----------------------|
|                                 | Total <sup>b</sup>    | Agriculture | Construction | Manufacturing, durable goods | Manufacturing, nondurable goods | Transportation, communication, and public utilities | Wholesale trade | Retail trade | Finance, insurance, and real estate | Business and repair services | Private household services | Personal services, except private household | Professional services | Public administration |
| Majority                        |                       |             |              |                              |                                 |   |                 |              |                                     |                              |                            |   |                       |                       |
| Males                           | 100.0                 | 5.1         | 8.8          | 16.9                         | 10.3                            | 8.4   | 5.4             | 14.3         | 5.0                                 | 4.2                          | 0.7                        | 1.5   | 11.6                  | 5.6                   |
| Females                         | 100.0                 | 2.1         | 1.2          | 7.8                          | 8.3                             | 3.8   | 2.7             | 21.0         | 7.1                                 | 2.6                          | 3.4                        | 3.6   | 30.6                  | 4.4                   |
| Black                           |                       |             |              |                              |                                 |   |                 |              |                                     |                              |                            |   |                       |                       |
| Males                           | 100.0                 | 3.5         | 7.3          | 18.8                         | 11.1                            | 11.5  | 3.8             | 11.1         | 3.4                                 | 3.6                          | 0.5                        | 2.1   | 12.8                  | 8.5                   |
| Females                         | 100.0                 | 1.2         | 0.3          | 6.3                          | 9.9                             | 4.0   | 1.0             | 11.1         | 5.4                                 | 1.8                          | 8.2                        | 4.4   | 38.2                  | 7.7                   |
| Hispanic                        |                       |             |              |                              |                                 |   |                 |              |                                     |                              |                            |   |                       |                       |
| Males                           | 100.0                 | 7.7         | 8.9          | 16.4                         | 10.8                            | 7.1   | 3.8             | 15.9         | 2.8                                 | 5.3                          | 0.4                        | 2.6   | 9.1                   | 6.0                   |
| Females                         | 100.0                 | 2.7         | 0.5          | 9.7                          | 16.1                            | 4.1   | 2.3             | 18.4         | 6.2                                 | 2.9                          | 5.6                        | 4.9   | 22.5                  | 3.1                   |
| Asian & Pacific Island American |                       |             |              |                              |                                 |   |                 |              |                                     |                              |                            |   |                       |                       |
| Males                           | 100.0                 | 6.7         | 3.5          | 8.2                          | 8.3                             | 4.8   | 6.7             | 23.0         | 4.5                                 | 4.5                          | 0.6                        | 3.5   | 17.8                  | 7.3                   |
| Females                         | 100.0                 | 2.0         | 0.7          | 3.1                          | 11.9                            | 2.7   | 2.4             | 19.8         | 7.2                                 | 2.3                          | 3.8                        | 5.3   | 33.2                  | 4.4                   |
| American Indian                 |                       |             |              |                              |                                 |   |                 |              |                                     |                              |                            |   |                       |                       |
| Males                           | 100.0                 | 6.7         | 15.6         | 16.7                         | 10.4                            | 9.2   | 3.0             | 10.4         | 2.2                                 | 6.6                          | 0.6                        | 1.0   | 7.1                   | 6.3                   |
| Females                         | 100.0                 | 3.7         | 0.8          | 8.3                          | 13.7                            | 1.5   | 1.2             | 21.6         | 6.0                                 | 2.7                          | 3.0                        | 4.8   | 26.6                  | 5.1                   |

<sup>a</sup> There were too few cases to show data for the mining and entertainment industries. As a result, industries shown will not add to 100 percent.

<sup>b</sup> Excludes persons covered by medicaid or medicare, receiving supplemental security income (SSI), public assistance, or welfare payments. See appendix A.

— Rounds to less than 1 percent.

Source: Special tabulations from the Survey of Income and Education, 1976.

**TABLE B.3****Percentage of Employed Persons 14 to 64 Years Old with Health Insurance Coverage, by Class of Worker, Race or Ethnicity, and Sex: 1976**

| Race or ethnicity and sex       | Class of worker    |         |            |               |
|---------------------------------|--------------------|---------|------------|---------------|
|                                 | Total <sup>a</sup> | Private | Government | Self-employed |
| Majority                        |                    |         |            |               |
| Males                           | 91.8               | 92.3    | 96.0       | 82.3          |
| Females                         | 92.0*              | 91.7*   | 95.6*      | 84.7*         |
| Black                           |                    |         |            |               |
| Males                           | 85.1               | 84.8    | 91.9       | 61.0          |
| Females                         | 88.1               | 85.8    | 93.6       | 83.5*         |
| Hispanic                        |                    |         |            |               |
| Males                           | 77.9               | 77.2    | 90.5       | 58.0          |
| Females                         | 81.1               | 81.0    | 86.8       | 67.6          |
| Asian & Pacific Island American |                    |         |            |               |
| Males                           | 84.4               | 83.8    | 93.9*      | 77.1*         |
| Females                         | 86.4               | 84.9    | 97.5*      | —             |
| American Indian                 |                    |         |            |               |
| Males                           | 74.4               | 77.5    | 76.9       | 42.0          |
| Females                         | 79.6               | 85.7    | 66.9       | —             |

<sup>a</sup> Excludes persons covered by medicaid or medicare, receiving supplemental security income (SSI), public assistance, or welfare payments. See appendix A.

\* The difference between this value and the corresponding value for majority males is not statistically significant at the 0.05 level of confidence. See appendix A for data source and sampling information.

— A value is not available due to an insufficient sample size. Appendix A contains the sample size for all population groups shown in each table.

Source: Special tabulations from the Survey of Income and Education, 1976.

**TABLE B.4****Percentage of Employed Persons 14 to 64 Years Old with Health Insurance Coverage, By Full-time or Part-time Status, Race or Ethnicity, and Sex: 1976**

| Race or ethnicity and sex       | Full-time or part-time employment status |                    |                                 |
|---------------------------------|--|--------------------|---------------------------------|
|                                 | Total <sup>a</sup>                       | Employed full time | Employed part time <sup>b</sup> |
| Majority                        |  |                    |                                 |
| Males                           | 91.8                                     | 92.6               | 85.7                            |
| Females                         | 92.0*                                    | 93.4               | 88.9                            |
| Black                           |  |                    |                                 |
| Males                           | 85.1                                     | 87.6               | 64.5                            |
| Females                         | 88.1                                     | 90.8               | 78.5                            |
| Hispanic                        |  |                    |                                 |
| Males                           | 77.9                                     | 80.2               | 58.5                            |
| Females                         | 81.1                                     | 83.5               | 73.4                            |
| Asian & Pacific Island American |  |                    |                                 |
| Males                           | 84.4                                     | 86.0               | 68.3                            |
| Females                         | 86.4                                     | 90.5               | 74.5                            |
| American Indian                 |  |                    |                                 |
| Males                           | 74.4                                     | 76.6               | 58.3                            |
| Females                         | 79.6                                     | 79.7               | 79.1*                           |

<sup>a</sup> Excludes persons covered by medicaid or medicare, receiving supplemental security income (SSI), public assistance, or welfare payments. See appendix A.

<sup>b</sup> A person is classified as a part-time worker if he or she worked less than 35 hours per week in a majority of weeks worked during 1975.

\* The difference between this value and the corresponding value for majority males is not statistically significant at the 0.05 level of confidence. See appendix A for data source and sampling information.

Source: Special tabulations from the Survey of Income and Education, 1976.

**TABLE B.5**  
**Percentage Distribution of Persons 14 to 64 Years Old by Total Family Income and Race or Ethnicity: 1976**

| Race or ethnicity | Total | Total family income |                 |                   |                   | Median   |
|-------------------|-------|---------------------|-----------------|-------------------|-------------------|----------|
|                   |       | Under \$5,000       | \$5,000-\$9,999 | \$10,000-\$14,000 | \$15,000 and over |          |
| Majority male     | 100.0 | 5.5                 | 14.1            | 21.7              | 58.7              | \$15,744 |
| Black             | 100.0 | 13.9                | 27.0            | 24.1              | 35.0              | \$11,887 |
| Hispanic          | 100.0 | 12.9                | 26.3            | 28.2              | 32.7              | \$11,922 |
| Asian & Pacific   |       |                     |                 |                   |                   |          |
| Island American   | 100.0 | 12.1                | 16.8            | 18.9              | 52.2              | \$15,211 |
| American Indian   | 100.0 | 17.2                | 26.8            | 24.1              | 31.9              | \$11,234 |

Note: Excludes persons covered by medicaid or medicare, receiving supplemental security income (SSI), public assistance, or welfare payments. See appendix A.

Source: Special tabulations from the Survey of Income and Education, 1976.

**TABLE B.6**  
**Percentage of Children 0 to 13 Years Old with Health Insurance Coverage, by Age and Race or Ethnicity: 1976**

| Race or ethnicity | Age of children |         |        |         |
|-------------------|-----------------|---------|--------|---------|
|                   | Total*          | Under 1 | 1 to 5 | 6 to 13 |
| Majority          | 91.7            | 89.6    | 90.5   | 92.5    |
| Black             | 77.4            | 71.1    | 77.8   | 77.7    |
| Hispanic          | 73.2            | 67.1    | 73.1   | 74.0    |
| Asian & Pacific   |                 |         |        |         |
| Island American   | 82.9            | 84.8*   | 85.7   | 80.6    |
| American Indian   | 59.7            | —       | 63.6   | 57.5    |

\* Excludes persons covered by medicaid or medicare, receiving supplemental security income (SSI), public assistance, or welfare payments. See appendix A.

\* The difference between this value and the corresponding value for majority children is not statistically significant at the 0.05 level of confidence. See appendix A for data source and sampling information.

— A value is not available due to an insufficient sample size. Appendix A contains the sample size for all population groups shown in each table.

Source: Special tabulations from the Survey of Income and Education, 1976.

**UNITED STATES  
COMMISSION ON  
CIVIL RIGHTS**  
WASHINGTON, D.C. 20425

OFFICIAL BUSINESS  
PENALTY FOR PRIVATE USE, \$300



POSTAGE AND FEES PAID  
U.S. COMMISSION ON CIVIL RIGHTS